



MEGABLOK

CATÁLOGO GENERAL
GENERAL CATALOGUE
CATALOGUE GENERAL
CATÁLOGO GERAL



MEGABLOK



MEGABLO



06

05

04



ESPACIOS **PARA CUIDAR DE TI**

SPACES **TO TAKE CARE OF YOU**

ESPACES **POUR PRENDRE SOIN DE VOUS**

ESPAÇOS **PARA CUIDAR DE VOCÊ**



CERTIFICADO DE ENSAYO nº 231.X.1805.257.ES.03

Referencia: 1803202-02-C

PRODUCTO: TAQUILLA METÁLICA SERIE MODULAR
EMPRESA: MEGABLOK, S. A.U.
PLATAFORMA LOGÍSTICA PLAZA, C/ PALERMO 7
50197 ZARAGOZA (ESPAÑA)
Tfno: 976 50 54 88
CIF: A 50711498

ENSAYO: Adecuación a las siguientes normas de especificaciones:
"UNE EN 16121:2014+A1:2017"
Mobiliario de almacenamiento de uso no doméstico.
Requisitos de seguridad, resistencia, durabilidad y estabilidad.
Nivel 2 Uso Severo.

RESULTADO: Cumple satisfactoriamente las especificaciones fijadas por la norma en los siguientes ensayos aplicables al modelo:

ENSAYOS	RESULTADO
Apto. 5 Requisitos generales de seguridad: Apto. 5.2 Requisitos generales de seguridad. Apto. 5.3 Puntos de cizalladura y pincamiento. Apto. 5.6 Estabilidad.	CORRECTO CORRECTO ESTABLE
Apto. 6.7 Seguridad estructural: Apto. 5.7.1.2 Ensayo de retención del entrepaño. Fuerza horizontal. (F _h > 50 N, n= 1 vez) Apto. 5.7.1.3 Ensayo de retención del entrepaño. Fuerza vertical. (F _v > 100 N, n= 1 vez) Apto. 5.7.1.4 Resistencia de los soportes del entrepaño. (Q= 10 kg, M= 1,7 kg, n= 10 veces) Apto. 5.7.1.5 Carga vertical de las puertas giratorias. (M= 30 kg, n= 10 veces) Apto. 5.7.1.6 Carga horizontal de las puertas giratorias. (F _h 60 N, n= 10 veces)	CORRECTO CORRECTO CORRECTO CORRECTO CORRECTO
Apto. 6. Resistencia y durabilidad: Apto. 6.1.1 Resistencia de los soportes de las barras para ropa. (Q= 4,0 kg/dm, t= 1 hora) Apto. 6.1.2 Resistencia de las perchas para la ropa (Q= 150N, n= 10 ciclos) Apto. 6.1.3 Durabilidad de las puertas giratorias. (M= 2,0 kg, n= 80.000 ciclos) Apto. 6.1.4 Ensayo de cierre brusco de las puertas giratorias. (M= 4,1 kg, n= 10 veces) Apto. 6.1.14 Ensayo de caída. (h = 90 mm) Apto. 6.1.15 Flexión de los entrepaños. (Q= 2,0kg/dm ² kg, t= 7 días) Apto. 6.1.16 Desprendimiento de las barras para la ropa. (Q= 5 kg/dm, t= 7 días)	CORRECTO CORRECTO CORRECTO CORRECTO CORRECTO CORRECTO

Palerna, 01 de Junio de 2018

Fco. José Emilio Nuévalos
Responsable Laboratorio de Muebles y Productos

El presente certificado únicamente concierne a las muestras ensayadas por el Laboratorio de AIDIMME.
Los resultados particulares del ensayo se encuentran descritos en el informe técnico Nº 231.1805.257.ES.03 del 31/05/2018.
AIDIMME es miembro de INNOMWOOD, la Red Europea de Innovación para la Industria Forestal, de la Madera y el Mueble, entre cuyos miembros se encuentran: BRE-CTIC (Reino Unido), COSMOB (Italia), DTT (Dinamarca), FCBA (Francia), ITO (Polonia), SHR (Polonia), SP (Suavia), TRISA-TRISA (Reino Unido), University of Zagreb (Croacia), WFG (Alemania).

AIDIMME: INSTITUTO TECNOLÓGICO METALMECÁNICO, MUEBLE, MADERA, EMBALAJE Y AFINES
Parque Tecnológico - Calle Basento Franklin, 12
C/P. C/CIUDAD 100-46500 INTERRA (Vareña) ESPAÑA
Tel: 96 136 60 70 - Fax: 96 136 61 85

aidimme@aidimme.es
www.aidimme.es

CERTIFICADO DE ENSAYO nº 231.X.1805.258.ES.03

Referencia: 1803202-01-C

PRODUCTO: TAQUILLA METÁLICA SERIE MONOBLOK
EMPRESA: MEGABLOK, S. A.U.
PLATAFORMA LOGÍSTICA PLAZA, C/ PALERMO 7
50197 ZARAGOZA (ESPAÑA)
Tfno: 976 50 54 88
CIF: A 50711498

ENSAYO: Adecuación a las siguientes normas de especificaciones:
"UNE EN 16121:2014+A1:2017"
Mobiliario de almacenamiento de uso no doméstico.
Requisitos de seguridad, resistencia, durabilidad y estabilidad.
Nivel 2 Uso Severo.

RESULTADO: Cumple satisfactoriamente las especificaciones fijadas por la norma en los siguientes ensayos aplicables al modelo:

ENSAYOS	RESULTADO
Apto. 5 Requisitos generales de seguridad: Apto. 5.2 Requisitos generales de seguridad. Apto. 5.3 Puntos de cizalladura y pincamiento. Apto. 5.6 Estabilidad.	CORRECTO CORRECTO ESTABLE
Apto. 6.7 Seguridad estructural: Apto. 5.7.1.2 Ensayo de retención del entrepaño. Fuerza horizontal. (F _h > 50 N, n= 1 vez) Apto. 5.7.1.3 Ensayo de retención del entrepaño. Fuerza vertical. (F _v > 100 N, n= 1 vez) Apto. 5.7.1.4 Resistencia de los soportes del entrepaño. (Q= 10 kg, M= 1,7 kg, n= 10 veces) Apto. 5.7.1.5 Carga vertical de las puertas giratorias. (M= 30 kg, n= 10 veces) Apto. 5.7.1.6 Carga horizontal de las puertas giratorias. (F _h 60 N, n= 10 veces) Apto. 5.7.1.15 Muebles que desmontan en el suelo. (F = 200 N)	CORRECTO CORRECTO CORRECTO CORRECTO CORRECTO CORRECTO
Apto. 6. Resistencia y durabilidad: Apto. 6.1.1 Resistencia de los soportes de las barras para ropa. (Q= 4,0 kg/dm, t= 1 hora) Apto. 6.1.2 Resistencia de las perchas para la ropa (Q= 150N, n= 10 ciclos) Apto. 6.1.3 Durabilidad de las puertas giratorias. (M= 2,0 kg, n= 80.000 ciclos) Apto. 6.1.4 Ensayo de cierre brusco de las puertas giratorias. (M= 4,1 kg, n= 10 veces) Apto. 6.1.15 Flexión de los entrepaños. (Q= 2,0kg/dm ² kg, t= 7 días) Apto. 6.1.16 Desprendimiento de las barras para la ropa. (Q= 5 kg/dm, t= 7 días)	CORRECTO CORRECTO CORRECTO CORRECTO CORRECTO CORRECTO

Palerna, 01 de Junio de 2018

Fco. José Emilio Nuévalos
Responsable Laboratorio de Muebles y Productos

El presente certificado únicamente concierne a las muestras ensayadas por el Laboratorio de AIDIMME.
Los resultados particulares del ensayo se encuentran descritos en el informe técnico Nº 231.1805.258.ES.03 del 31/05/2018.
AIDIMME es miembro de INNOMWOOD, la Red Europea de Innovación para la Industria Forestal, de la Madera y el Mueble, entre cuyos miembros se encuentran: BRE-CTIC (Reino Unido), COSMOB (Italia), DTT (Dinamarca), FCBA (Francia), ITO (Polonia), SHR (Polonia), SP (Suavia), TRISA-TRISA (Reino Unido), University of Zagreb (Croacia), WFG (Alemania).

AIDIMME: INSTITUTO TECNOLÓGICO METALMECÁNICO, MUEBLE, MADERA, EMBALAJE Y AFINES
Parque Tecnológico - Calle Basento Franklin, 12
C/P. C/CIUDAD 100-46500 INTERRA (Vareña) ESPAÑA
Tel: 96 136 60 70 - Fax: 96 136 61 85

aidimme@aidimme.es
www.aidimme.es

El **Marcado CE**, es una exigencia obligatoria de carácter reglamentario para la comercialización de productos, en el mercado de cualquiera de los países que integran la Unión Europea. A su vez, especificar que también el **Marcado CE** en un equipo de trabajo es obligatorio. **MEGABLOK** cumple el **Marcado CE**.

The **CE-Mark** is an obligatory requirement of duly character for the commercialization of products, in the market of any of the countries which constitute the European Union. At the same time, to specify that the **CE-Mark** is also obligatory at any working equipment. **MEGABLOK**, complies with the **CE-Mark**.

Le **marquage CE** est une exigence à caractère réglementaire pour la commercialisation de produits sur les marchés de tous le pays qui conforment l'Union Européenne. De la même manière préciser que le **marquage CE** dans un outil de travail est obligatoire. **MEGABLOK** respecte le **marquage CE**.

A **Marcação CE**, é uma exigência obrigatória de carácter regulamentar para a comercialização de produtos, no mercado de qualquer um dos países que integram a União Europeia. Por sua vez, especificar que também a **Marcação CE** em uma equipe de trabalho é obrigatória. **MEGABLOK** cumpre a **Marcação CE**.

ISO 9001
BUREAU VERITAS
Certification



ISO 14001
BUREAU VERITAS
Certification



ISO 14006
BUREAU VERITAS
Certification



Bureau Veritas Certification

Certificación
Concedida a
MEGABLOK SAU

CL PALERMO, 7 PLATAFORMA LOGÍSTICA PLAZA - 50197 - ZARAGOZA - ESPAÑA

Bureau Veritas Certification certifica que el Sistema de Gestión ha sido auditado y encontrado conforme con los requisitos de la norma:

NORMA

ISO 9001:2015

El Sistema de Gestión se aplica a:

DISEÑO, DESARROLLO, FABRICACIÓN Y COMERCIALIZACIÓN DE MOBILIARIO PARA COLECTIVIDADES.

Table with 2 columns: Field (Número del Certificado, Aprobación original, etc.) and Value (ES113843-1, 08-10-2012, etc.)

Este certificado está sujeto a las normas y condiciones generales y particulares de los servicios de certificación

Bureau Veritas Iberia S.L. C/ Valparaiso Primera 22-24, Edificio Cosma, 28108 Alcobendas - Madrid, España



Bureau Veritas Certification

Certificación
Concedida a
MEGABLOK SAU

CL PALERMO, 7 PLATAFORMA LOGÍSTICA PLAZA - 50197 - ZARAGOZA - ESPAÑA

Bureau Veritas Certification certifica que el Sistema de Gestión ha sido auditado y encontrado conforme con los requisitos de la norma:

NORMA

ISO 14001:2015

El Sistema de Gestión se aplica a:

DISEÑO, DESARROLLO, FABRICACIÓN Y COMERCIALIZACIÓN DE MOBILIARIO PARA COLECTIVIDADES.

Table with 2 columns: Field (Número del Certificado, Aprobación original, etc.) and Value (ES113842-1, 08-04-2010, etc.)

Este certificado está sujeto a las normas y condiciones generales y particulares de los servicios de certificación

Bureau Veritas Iberia S.L. C/ Valparaiso Primera 22-24, Edificio Cosma, 28108 Alcobendas - Madrid, España



Certificación
Concedida a / Awarded to
MEGABLOK SAU

CL PALERMO, 7 PLATAFORMA LOGÍSTICA PLAZA - 50197 ZARAGOZA - SPAIN

Bureau Veritas Certification certifica que el Sistema de Gestión ha sido auditado y encontrado conforme con los requisitos de la norma:

NORMA / STANDARD

ISO 14006:2011

El Sistema de Gestión se aplica a
Scope of certification

DISEÑO, DESARROLLO, FABRICACIÓN Y COMERCIALIZACIÓN DE MOBILIARIO METÁLICO.

DESIGN, DEVELOPMENT, MANUFACTURING AND COMMERCIALIZATION OF METALLIC FURNITURE.

Table with 2 columns: Field (Número del certificado, Aprobación original, etc.) and Value (ES107819-1, 22/10/2011, etc.)

Signature of Certification Manager

Este certificado está sujeto a las normas y condiciones generales y particulares de los servicios de certificación

Bureau Veritas Certification Iberia, Bureau Veritas Iberia S.L. C/ Valparaiso Primera 22-24, Edificio Cosma, Pw. 1º, La Serna, 28108 Alcobendas - Madrid, Spain

Certificate SGSCH-COC-002085
SGSCH-CW-002085

The Organization

Setra Trävaror AB
Gårdsvägen 18,
169 03 Soana, Sweden

has been assessed and certified as meeting the requirements of

FSC® Chain-of-Custody

The company was assessed against the following standards:
FSC-STD-40-003 V2-1 Chain of Custody Certification of Multiple Sites - November 2014,
FSC-STD-40-004 Version 3.0 FSC Standard for Chain of Custody Certification - April 2017,
FSC-STD-40-005 V3-1 Requirements for Sourcing FSC® Controlled Wood - February 2017,
FSC-STD-40-001 Requirements for use of the FSC trademarks by Certificate Holders

The scope of the record appears on page 2 of this certificate

This certificate is valid from 23 October 2020 until 23 March 2025 and remains valid subject to satisfactory surveillance audits.

Re-certification audit due 90 days prior to expiry date.
Issue 15. Certified since March 2010
SGS Ref # SE1002016

This is a multi-site certification scheme
Additional site details are listed on subsequent pages

Authorized by

Signatures of authorized personnel

SGS Société Générale de Surveillance SA
1 place des Alpes, 1211 Geneva, Switzerland
+41 (0)22 739 81 11 / +41 (0)22 739 88 88 www.sgs.com



The mark of responsible forestry

This certificate shall cover all activities unless there is a specific exclusion in the scope of the certificate when the required FSC data is being prepared and delivery documents. The certificate holder is responsible for ensuring that the certificate and all other data is correct and up-to-date. The certificate and all other data is subject to verification by SGS.

Page 1 of 2

Certificate SGSCH-COC-002085 & SGSCH-CW-002085
continued

Setra Trävaror AB
FSC® Chain-of-Custody

Issue 15

Detailed scope

The purchasing of round wood (FSC 100%, FSC Mix, FSC Controlled Wood and Controlled Wood) and sawn timber (FSC Mix, FSC Controlled Wood, Controlled Wood), manufacturing and sale (credit system) of sawn timber, round wood, pulp chips, sawdust and engineered solid wood products (FSC Mix and FSC Controlled Wood). Outsourced planing at FSC certified outsourcing partners.

Additional facilities

Setra Fårla - Snaabäcken, 62041 Fårla, Sweden
Setra Hasselöfs - Edevägen, 69365 Hasselöfs, Sweden
Setra Heby - Claes Wikströms Väg 3, 74432 Heby, Sweden
Setra Kastet - Korsnåsvägen 151, 80105 Gävle, Sweden
Setra Mala - Storgatan 75, 83070 Malå, Sweden
Setra Nyby - Nybyvägen 8, 74363 Björkinge, Sweden
Setra Skinnkatteberg - Näsavägen, 73933 Skinnkatteberg, Sweden
Setra Långshyttan - Amungsvägen 17, 77070 Långshyttan, Sweden
Setra Gävle - Skolgången 13, Box 223, Gävle, Sweden



The mark of responsible forestry

This document is issued by the Company subject to its General Conditions of Certification. SGS reserves the right to amend, modify, suspend, or terminate the certification at any time without notice. The validity of this document may be affected if the certificate holder fails to comply with the requirements of the certification scheme. The certificate holder is responsible for ensuring that the certificate and all other data is correct and up-to-date. The certificate and all other data is subject to verification by SGS.

Page 2 of 2

Certificate SE100231

The organization

Setra Trävaror AB
Gårdsvägen 18, 169 03 Soana, Sweden

has been assessed and certified as meeting the requirements of the standard

PEFC - Chain of Custody

PEFC ST 2002:2013 - "Chain of Custody of Forest Based Products - Requirements" - dated 24/05/2013
PEFC ST 201:2008, Second Edition - "PEFC Logo Usage Rules - Requirements" - dated 26/11/2010 as amended and published by www.pefc.org

This certification includes the following products

Purchase of PEFC certified, PEFC controlled sources and other material spruce and pine round wood and sawn timber. Manufacturing and sale of PEFC certified sawn timber, round wood, engineered solid wood products and sawmill by-products using the percentage-based method.

This certificate is valid from 27 April 2020 until 26 April 2025 and remains valid subject to satisfactory surveillance audits.
Recertification audit due 60 days prior to expiry date
Issue 4. Certified since April 2005

This is a multi-site certification scheme
Additional site details are listed on the subsequent page

Authorized by

Signatures of authorized personnel

SGS Société Générale de Surveillance SA
1 place des Alpes, 1211 Geneva, Switzerland
+41 (0)22 739 81 11 / +41 (0)22 739 88 88 www.sgs.com

Organizations with a valid PEFC chain of custody certificate can only use the PEFC Logo with unique PEFC license tag number based on PEFC Logo usage license contract issued by the PEFC Council or another entity authorized by the PEFC Council and in accordance with the PEFC Logo usage rules.

Page 1 of 2

This document is issued by the Company subject to its General Conditions of Certification. SGS reserves the right to amend, modify, suspend, or terminate the certification at any time without notice. The validity of this document may be affected if the certificate holder fails to comply with the requirements of the certification scheme. The certificate holder is responsible for ensuring that the certificate and all other data is correct and up-to-date. The certificate and all other data is subject to verification by SGS.

Certificate SE100231, continued

Setra Trävaror AB
PEFC - Chain of Custody

Issue 4

This certification includes the following products

The scope of registration appears on page 1 of this certificate.

Additional facilities

Setra Fårla, Snaabäcken, Fårla, 620 41, Sweden
Setra Hasselöfs, Edevägen, Hasselöfs, 695 85, Sweden
Setra Heby, Claes Wikströms Väg 3, Heby, 744 32, Sweden
Setra Kastet, Korsnåsvägen 151, Gävle, 801 05, Sweden
Setra Mala, Storgatan 75, Malå, 830 70, Sweden
Setra Nyby, Nybyvägen 8, Björkinge, 743 63, Sweden
Setra Skinnkatteberg, Näsavägen, Skinnkatteberg, 739 33, Sweden
Setra Långshyttan, Amungsvägen 17, Långshyttan, 770 70, Sweden
Setra Gävle, Skolgången 13, Box 223, Gävle, 801 04, Sweden



The mark of responsible forestry

This document is issued by the Company subject to its General Conditions of Certification. SGS reserves the right to amend, modify, suspend, or terminate the certification at any time without notice. The validity of this document may be affected if the certificate holder fails to comply with the requirements of the certification scheme. The certificate holder is responsible for ensuring that the certificate and all other data is correct and up-to-date. The certificate and all other data is subject to verification by SGS.

Page 2 of 2

1	TAQUILLAS ECO	Eco lockers	Vestiaires Eco	Cacifos Eco	pag. 8 - 11
	TAQUILLAS MODULARES	Disassembled lockers	Vestiaires demontables	Cacifos desmontáveis	pag. 12 - 15
	SERIE GYM	Gym series	Série Gym	Série Gym	pag. 16
	SERIE CHASIS+BANCO	Chassis series	Série Chasis	Série Chasis	pag. 17
2	TAQUILLAS MONOBLOK	Monoblok lockers	Vestiaires monoblok	Cacifos monoblok	pag. 18 - 21
	CONSIGNAS BAJO BANCO	Lockers for bench seats	Consignes pour bancs	Cacifos para bancos	pag. 24
	PERSONALIZACIÓN LUX	Lux personalisations	Sur mesure Lux	Customizado Lux	pag. 25
	TAQUILLAS MULTIPUERTA	Multidoor lockers	Casiers visitables	Cacifos multiportas	pag. 26 - 27
	TAQUILLAS INOX	Inox lockers	Vestiaires Inox	Armários de vestiário Inox	pag. 28 - 31
	TAQUILLA MATERIAL LIMPIEZA	Cleanning material locker	Armoire pour materiel de enttoyage	Armario de limpeza	pag. 34
	TAQUILLA LAVANDERÍA	Laundry bulk collector locker	Armoire a linge	Cacifo lavanderia	pag. 34
	TAQUILLAS SKI	Ski lockers	Vestiaires à Ski	Cacifos Ski	pag. 35
3	SERIES BANCO/MINI/SUPERMERCADO	Banco/Mini/Supermercado series	Séries Banco/Mini/Supermercado	Séries Banco/Mini/Supermercado	pag. 38
	SERIE MARCO AMARRE	Marco amarre series	Série Marco amarre	Série Marco amarre	pag. 39
	SERIE MONOBLOK METACRILATO	Monoblok metacrilato series	Série Monoblok metacrilato	Série Monoblok metacrilato	pag. 40
	SERIE GOLF / SERIE MALETAS	Golf series / Suitcase series	Série Golf / Série Valises	Série Golf / Série Malas	pag. 41
	DEPARTAMENTOS	Compartmens	Casiers	Cacifos	pag. 42 - 43
	ARMARIOS DE OFICINA Y TALLER	Office and industrial cabinets	Armoires de bureau et atelier	Armários de escritorio	pag. 44 - 45
	ARMARIOS METÁLICOS DE PERSIANA PVC	Metal cabinet with PVC rolling door	Armoire métallique a rideau PVC	Armários de escritorio	pag. 46 - 47
4	TAQUILLAS MELAMINA HIDRÓFUGA	Hydrophobic melamine lockers	Vestiaires en mélamine hydrofuge	Cacifos de melamina hidrófuga	pag. 50 - 55
	TAQUILLAS FENÓLICAS	HPL lockers	Vestiaires en stratifié	Cacifos de resinas fenólicas	pag. 56 - 61
	CABINAS FENÓLICAS	HPL-cubicles	Cabines en stratifié	Cabines fenólicas	pag. 62 - 63
5	BANCOS EN ACERO	Steel bench seats	Bancs en acier	Bancos em aço	pag. 65
	BANCOS EN MADERA Y ACERO	Wooden and steel bench seats	Bancs en bois et acier	Bancos em madeira e aço	pag. 66 - 68
	BANCOS EN MELAMINA	Bench in melamine	Bancs en mélamine	Bancos em melamina	pag. 69
	BANCOS EN FENÓLICO	Phenolic bench seats	Bancs en stratifié massif	Bancos em fórmica	pag. 70 - 73
	BANCOS EN PVC	PVC bench seats	Bancs en PVC	Bancos em PVC	pag. 74 - 75
	PERCHEROS Y REPISAS	Hooks and racks	Crochets	Cabides	pag. 76 - 77
	MESAS Y BANCOS DE COMEDOR	Tables and benches for dining rooms	Des tables et des bancs pour salle à manger	Mesas e bancos para sala	pag. 78 - 79
	TAQUILLAS DE PLÁSTICO	Plastic lockers	Vestiaires en plástico	Armários em plástico	pag. 80 - 81
	ARMARIOS EN RESINA DE POLIPROPILENO	Polypropylene resin cupboards	Armoires en resine de polypropilene	Armários em resina de polipropilene	pag. 82 - 83
	CERRADURAS	Locks	Serrures	Fechaduras	pag. 84 - 85
6	CHARGING BOXES	Charging boxes	Charging boxes	Charging boxes	pag. 86 - 89
	CHARGING CARTS	Charging carts	Charging carts	Charging carts	pag. 90 - 93
	MONOBLOK-E	Monoblok-E	Monoblok-E	Monoblok-E	pag. 94 - 97
	OPEN SPACES	Open Spaces	Open Spaces	Open Spaces	pag. 98 - 101
	NOVEDADES	News	Nouveautés	Novidades	pag. 102-104

AMBIENTE SECO / DRY ENVIRONMENT / ENVIRONNEMENT SEC / AMBIENTE SECO



AMBIENTE HÚMEDO / WET ENVIRONMENT / ENVIRONNEMENT HUMIDE / AMBIENTE ÚMIDO



AMBIENTE EXTREMADAMENTE HÚMEDO / EXTREMELY WET ENVIRONMENT / ENVIRONNEMENT EXTRÊMEMENT HUMIDE
AMBIENTE EXTREMADAMENTE ÚMIDO



TAQUILLAS ELECTRÓNICAS
ELECTRONIC LOCKERS
VESTIAIRES ÉLECTRONIQUES
CACIFOS ELETRÔNICOS

BANCOS DE VESTUARIO / ACCESORIOS DE VESTUARIO
BENCH SEATS / BANCS POUR VESTIAIRES
BANCOS DE VESTIÁRIO /CHANGING ROOM ACCESORIES
ACCESSORIES POUR VESTIAIRES / MOBILIÁRIO PARA O BANHEIRO

TAQUILLAS NO METÁLICAS
NON-METALLIC LOCKERS
VESTIAIRES NON MÉTALLIQUES
CACIFOS NÃO METÁLICOS

CONSIGNAS
LEFT-LUGGAGE LOCKERS
CONSIGNES
CACIFOS

TAQUILLAS METÁLICAS MONOBLOK
MONOBLOK METAL LOCKERS
VESTIAIRES MÉTALLIQUES MONOBLOK
CACIFOS DE METAL MONOBLOK

TAQUILLAS METÁLICAS
METAL LOCKERS
VESTIAIRES MÉTALLIQUES
CACIFOS DE METAL

TAQUILLAS METÁLICAS

METAL LOCKERS / VESTIAIRES MÉTALLIQUES / CACIFOS DE METAL

CARACTERÍSTICAS / CHARACTERISTICS / CARACTERISTIQUES / CHARACTERISTICAS

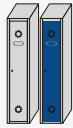

Estándar: Cuerpo gris y puertas azul o gris.
Standard: Grey body and blue or grey doors.
Standard: Corp gris et portes bleu ou gris.
Padrão: Corpo cinza e portas azuis ou cinza.

RAL 7035 RAL 5010



Metal.
Metal.
Metal.
Metal.



Gran resistencia.
High resistance.
Très résistant.
Muito resistente.



Cerradura de llave.
Standard key lock.
Serrure standard à clé.
Fechadura standard de chave.



Espesores.
Thicknesses.
Épaisseurs.
Espessura.



Etiquetero y rosetas de ventilación.
Card holder and vent system.
Porte-étiquette et volets d'aération.
Placa de numeração e ventilação.

EPOXI

Pintado en Epoxi.
Painted in Epoxy.
Peinture en epoxi.
Pintura em epoxi.



No es recomendable para espacios húmedos.
Not recommended for wet spaces.
Pas recommandé pour les environnements humides.
Nao é recomendável para lugares com humidade.

**MICRO
TEX**

Microtexturado.
Microtextured.
Microtexturé.
Microtexturado.

OPCIONES / OPTIONS / OPTIONS / OPÇÕES



Ranura buzón.
Mailbox Slot.
Fente boîte aux lettres.
Obertura para cartas.



Patas regulables en PVC.
Adjustable PVC Legs.
Pieds réglables en PVC.
Pés reguláveis em altura em PVC.



Patas en acero galvanizado pintado.
Painted galvanized steel legs.
Pieds en acier galvanisé peint.
Pés em aço galvanizado pintado.



Sobretecho inclinado.
Slope Top.
Toit incliné.
Sobreteto com inclinação.



Altillo.
Upper small joined locker.
Casier en hauteur.
Pequeno cacifo para pôr encima do cacifo.



Zócalo inoxidable/galvanizado/galvanizado pintado.
Stainless steel base/galvanized/painted galvanized.
Socle inoxydable/galvanisé/galvanisé peint.
Soclo inox/galvanizado/galvanizado pintado.



Espejo.
Mirror.
Miroir.
Espelho.



Pulsera de nylon.
Nylon bracelet.
Bracelet en nylon.
Pulseira de náilon.



Pulsera elástica.
Elastic Bracelet.
Bracelet élastique.
Pulseira elástica.



Pintura antibacteriana.
Antibacterial paint.
Peinture antibactérienne.
Tinta antibacteriana.

SISTEMAS DE APERTURA / OPENING SYSTEM /
SYSTÈMES D'OUVERTURE / SISTEMA DE ABERTURA

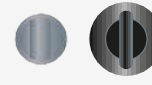

Pomo en poliamida / metálico.
Padlockable polyamide Lock / metallic Lock.
Serrure à porte cadenas en polyamide/métallique
Fechadura de cadeado em poliamida / metal.



Cerradura de combinación y llave de emergencia.
Manual combination lock with emergency key.
Serrure à combinaison de 4 chiffres et clé de secours.
Fechadura de combinação e chave de emergência.



Tirador metálico.
Metal handle.
Poignée en métal.
Cabo de metal.



Imán.
Magnet.
Aimant.
Magnético.



Monedero con moneda retornable/con cajetín depósito.
Coin-operated Lock with coin-return/collect box.
Monnayeur avec monnaie retournable/tirelire.
Moedeiro moeda retornável/caixinha.



Cerraduras electrónicas de combinación de 4 dígitos.
Electronic combination locks of 4 digits.
Serrures électroniques à combinaison de 4 chiffres.
Fechaduras electrónicas, combinação de 4 dígitos.



Cerraduras de proximidad.
RFID Locks.
Serrures de proximité.
Fechaduras de proximidade.

COLORES OPCIONALES PUERTAS Y CUERPO / OPTIONAL DOOR AND BODY COLOURS / COULEURS OPTIONNELS POUR CORPS ET PORTES / CORES DE PORTAS E CORPO OPCIONAIS



RAL 9010 RAL 9001 RAL 1017 RAL 1021 RAL 2004 RAL 4010 RAL 3017 RAL 3000 RAL 3005 RAL 4005 RAL 6029 RAL 6034 RAL 5015 RAL 5023 RAL 5010 RAL 8025 RAL 7035 RAL 9006 RAL 7036 RAL 7016 RAL 9005

TAQUILLAS METÁLICAS

METAL LOCKERS / VESTIAIRES MÉTALLIQUES / CACIFOS DE METAL



TAQUILLAS ECO
ECO LOCKERS /
VESTIAIRES ECO /
CACIFOS ECO



TAQUILLAS MODULARES
DISASSEMBLED LOCKERS /
VESTIAIRES DEMONTABLES /
CACIFOS DESMONTÁVEIS



TAQUILLAS MONOBLOK
MONOBLOK LOCKERS /
VESTIAIRES MONOBLOK /
CACIFOS MONOBLOK



Montaje

Assembly/Montage/Montagem



Con tornillos/With screws
Avec vis/Com parafusos



Sin tornillos/Without screws
Sans vis/Sem parafusos



Estructura soldada/Welded structure
Structure soudée/Estrutura soldada

Patas

Legs/Pieds/Pés



Opcional/Optional
En option/Opcional



Opcional/Optional
En option/Opcional



De serie/Standard/
Standard/ Como padrão

Acabado /Finish/Finition/Acabamento

Trasera y bandejas /Back panel and shelves/
Partie arrière et tablettes/Parte de atrás e Prateleiras

GALVA

Galvanizada/Galvanized
Acier galvanisé/Aço galvanizado

GALVA

Galvanizada/Galvanized
Acier galvanisé/Aço galvanizado



Pintado/Painted
Peint/ Pintado

Refuerzo/Reinforcement/Reinforcement/Reforço

Refuerzo Serie V
Reinforcement/Reinforcement/Reforço



Refuerzo Serie T-40
Reinforcement/Reinforcement/Reforço



Canto hexagonal
Hexagonal edge/Bord hexagonal/Borda hexagonal



Opcional /Optional/En option/Opcional

Divisoria Serie V-40
Divider/Séparation industrie salissante/Divisor



Lateral embellecedor
Decorative end panel/Enjoliveur latéral/Lateral de finição



Bandeja Serie V

Shelf/Tablette/Prateleira



Colgador Serie T

Coat rod/Porte cintres/Barra de cabides



Rigidez

Rigidity/Rigidité/Rigidez





TAQUILLAS ECO

ECO LOCKERS / VESTIAIRES ECO / ARMÁRIOS DE VESTIÁRIO ECO



SERIE ECOV

1 Puerta
Door
Porte
Porta



SERIE ECOT

2 Puertas
Doors
Portes
Portas



SERIE ECOM

3 Puertas
Doors
Portes
Portas



SERIE ECOC

4 Puertas
Doors
Portes
Portas



SERIE ECOP

5 Puertas
Doors
Portes
Portas



SERIE ECOB

6 Puertas
Doors
Portes
Portas



SERIE ECOZ

8 Puertas
Doors
Portes
Portas



SERIE ECOL

Puertas en forma de L
L-shaped doors
Portes en forme de L
Portas em L





**Patas opcionales/Optional legs/
 Pieds en option/Pés opcionais**



**Patas en acero galvanizado pintado/
 Painted galvanized steel legs/
 Pieds en acier galvanisé peint/
 Pés em aço galvanizado pintado.**



**Patas regulables en PVC/Adjustable PVC Legs/
 Pieds réglables en PVC/Pés reguláveis em altura em PVC.**

**Detalles constructivos/Construction details/
 Détails de la construction/Detalhes de construção**



**Unión de estructura/Structural joints/
 Liaison des structures/Ligação da estrutura.**



Interior **SERIE ECOV**



Interior **SERIE ECOT**

Cerraduras/Locks/Serrures/Fechaduras



**Cerradura con llave/Lock with key/
 Serrure à clé/Fechadura com chave.**



**Pomo metálico/Padlockable metal lock/
 Poignée métallique/Fechadura de cadeado em metal.**



**Pomo en poliamida/Padlockable polyamide lock/
 Poignée en polyamide/Fechadura de cadeado em poliamida.**



SERIE ECOV



ECOV-25/1
 COD: 82501
 16,7kg · 0,22m³

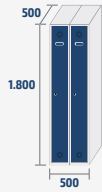

ECOV-25/2
 COD: 82502
 27,9kg · 0,45m³



ECOV-25/3
 COD: 82503
 39,1kg · 0,67m³

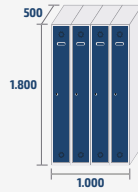

ECOV-25/4
 COD: 82504
 50,3kg · 0,9m³

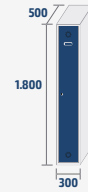

ECOV-30/1
 COD: 83001
 19kg · 0,27m³

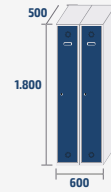

ECOV-30/2
 COD: 83002
 30,2kg · 0,54m³

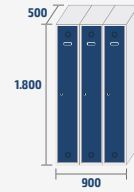

ECOV-30/3
 COD: 83003
 46kg · 0,81m³

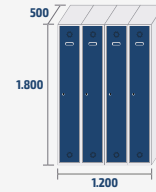

ECOV-30/4
 COD: 83004
 59,5kg · 1,08m³

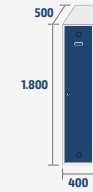

ECOV-40/1
 COD: 68651
 20,3kg · 0,36m³

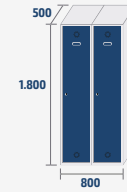

ECOV-40/2
 COD: 68652
 35,1kg · 0,72m³

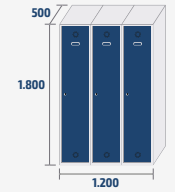

ECOV-40/3
 COD: 68653
 49,9kg · 1,08m³

SERIE ECOT

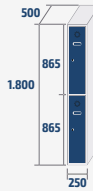

ECOT-25/1
 COD: 82551
 18,4kg · 0,22m³



ECOT-25/2
 COD: 82512
 31,3kg · 0,45m³



ECOT-25/3
 COD: 82513
 44,2kg · 0,67m³

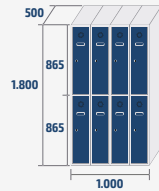

ECOT-25/4
 COD: 82514
 57,1kg · 0,9m³

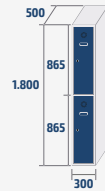

ECOT-30/1
 COD: 83011
 19,1kg · 0,27m³

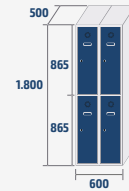

ECOT-30/2
 COD: 83012
 33,2kg · 0,54m³



ECOT-30/3
 COD: 83013
 47,3kg · 0,81m³

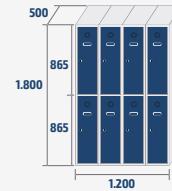

ECOT-30/4
 COD: 83014
 61,4kg · 1,08m³

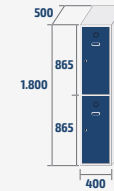

ECOT-40/1
 COD: 84011
 23kg · 0,36m³

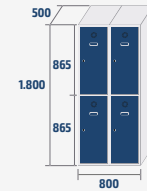

ECOT-40/2
 COD: 84012
 41kg · 0,72m³



ECOT-40/3
 COD: 84013
 59kg · 1,08m³

SERIE ECOM

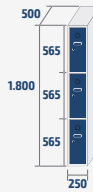

ECOM-25/1
 COD: 82531
 19,9kg · 0,22m³

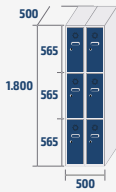

ECOM-25/2
 COD: 82532
 33,8kg · 0,45m³



ECOM-25/3
 COD: 82533
 47,7kg · 0,67m³

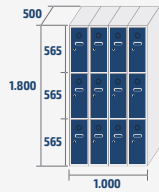

ECOM-25/4
 COD: 82534
 61,6kg · 0,9m³

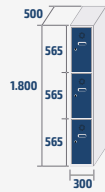

ECOM-30/1
 COD: 83031
 21,2kg · 0,27m³

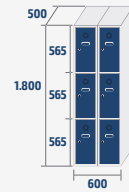

ECOM-30/2
 COD: 83032
 36,4kg · 0,54m³

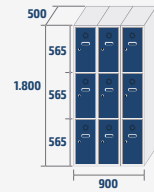

ECOM-30/3
 COD: 83033
 51,6kg · 0,81m³

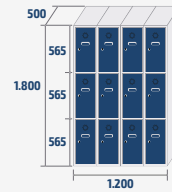

ECOM-30/4
 COD: 83034
 66,8kg · 1,08m³

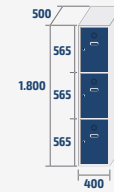

ECOM-40/1
 COD: 84031
 24,2kg · 0,36m³



ECOM-40/2
 COD: 84032
 42,4kg · 0,72m³



ECOM-40/3
 COD: 84033
 60,6kg · 1,08m³

SERIE ECOC

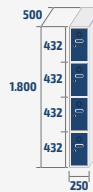

ECOC-25/1
 COD: 82521
 20,8kg · 0,22m³

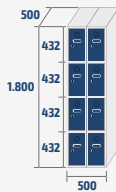

ECOC-25/2
 COD: 82522
 35,6kg · 0,45m³

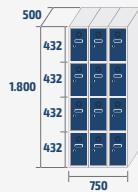

ECOC-25/3
 COD: 82523
 50,4kg · 0,67m³

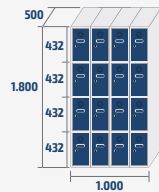

ECOC-25/4
 COD: 82524
 65,2kg · 0,9m³

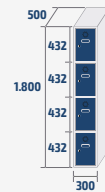

ECOC-30/1
 COD: 83021
 22,3kg · 0,27m³

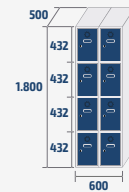

ECOC-30/2
 COD: 83022
 38,6kg · 0,54m³

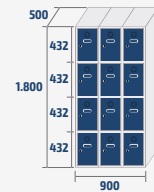

ECOC-30/3
 COD: 83023
 54,9kg · 0,81m³

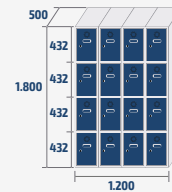

ECOC-30/4
 COD: 83024
 71,2kg · 1,08m³

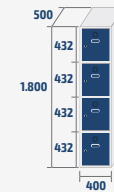

ECOC-40/1
 COD: 84021
 25,7kg · 0,36m³

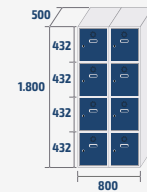

ECOC-40/2
 COD: 84022
 45,4kg · 0,72m³



ECOC-40/3
 COD: 84023
 65,1kg · 1,08m³



SERIE ECOP

ECOP-25/1 COD: 82621 21,7kg · 0,22m ³	ECOP-25/2 COD: 82622 38,4kg · 0,45m ³	ECOP-25/3 COD: 82623 55,1kg · 0,67m ³	ECOP-25/4 COD: 82624 71,8kg · 0,9m ³	ECOP-30/1 COD: 83621 23,4kg · 0,27m ³	ECOP-30/2 COD: 83062 40,9kg · 0,54m ³	ECOP-30/3 COD: 83063 58,4kg · 0,81m ³	ECOP-30/4 COD: 83064 75,9kg · 1,08m ³	ECOP-40/1 COD: 84061 27,1kg · 0,36m ³	ECOP-40/2 COD: 84062 48,3kg · 0,72m ³	ECOP-40/3 COD: 84063 69,5kg · 1,08m ³

SERIE ECOB

ECOB-25/1 COD: 82721 22,6kg · 0,22m ³	ECOB-25/2 COD: 82722 40,2kg · 0,45m ³	ECOB-25/3 COD: 82723 57,8kg · 0,67m ³	ECOB-25/4 COD: 82724 75,4kg · 0,9m ³	ECOB-30/1 COD: 83721 24,5kg · 0,27m ³	ECOB-30/2 COD: 83722 44kg · 0,54m ³	ECOB-30/3 COD: 83723 63,5kg · 0,81m ³	ECOB-30/4 COD: 83724 83kg · 1,08m ³	ECOB-40/1 COD: 84721 28,1kg · 0,36m ³	ECOB-40/2 COD: 84722 51,2kg · 0,72m ³	ECOB-40/3 COD: 84723 74,3kg · 1,08m ³

SERIE ECOZ

ECOZ-25/1 COD: 82581 24,4kg · 0,22m ³	ECOZ-25/2 COD: 82582 43,8kg · 0,45m ³	ECOZ-25/3 COD: 82583 63,2kg · 0,67m ³	ECOZ-25/4 COD: 82584 82,6kg · 0,9m ³	ECOZ-30/1 COD: 83821 26,7kg · 0,27m ³	ECOZ-30/2 COD: 83822 48,4kg · 0,54m ³	ECOZ-30/3 COD: 83823 70,1kg · 0,81m ³	ECOZ-30/4 COD: 83824 91,8kg · 1,08m ³	ECOZ-40/1 COD: 84821 30,9kg · 0,36m ³	ECOZ-40/2 COD: 84822 56,8kg · 0,72m ³	ECOZ-40/3 COD: 84823 82,7kg · 1,08m ³

SERIE ECOL

ECOL-30/1 COD: 35301 24,4kg · 0,27m ³	ECOL-30/2 COD: 35302 42,9kg · 0,54m ³	ECOL-30/3 COD: 35303 61,3kg · 0,81m ³	ECOL-30/4 COD: 35304 79,8kg · 1,08m ³	ECOL-40/1 COD: 35401 28,1kg · 0,36m ³	ECOL-40/2 COD: 35402 50,2kg · 0,72m ³	ECOL-40/3 COD: 35403 72,3kg · 1,08m ³



TAQUILLAS MODULARES

DISASSEMBLED LOCKERS / VESTIAIRES DEMONTABLES / ARMÁRIOS DE VESTIÁRIO DESMONTÁVEIS



SERIE AV

1 Puerta
Door
Porte
Porta



SERIE AT

2 Puertas
Doors
Portes
Portas



SERIE AM

3 Puertas
Doors
Portes
Portas



SERIE AC

4 Puertas
Doors
Portes
Portas



SERIE AP

5 Puertas
Doors
Portes
Portas

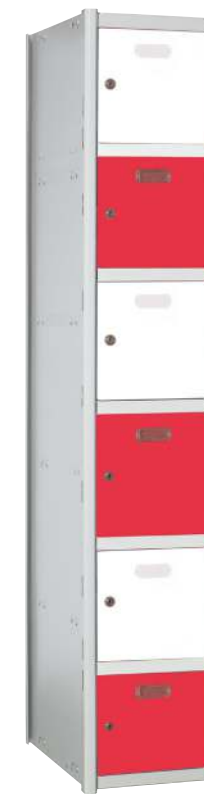

SERIE AB

6 Puertas
Doors
Portes
Portas



SERIE AZ

8 Puertas
Doors
Portes
Portas





Detalles constructivos/Construction details/
Détails de la construction/Detalhes de construção



Interior **AT-30**



Interior **AV-30**

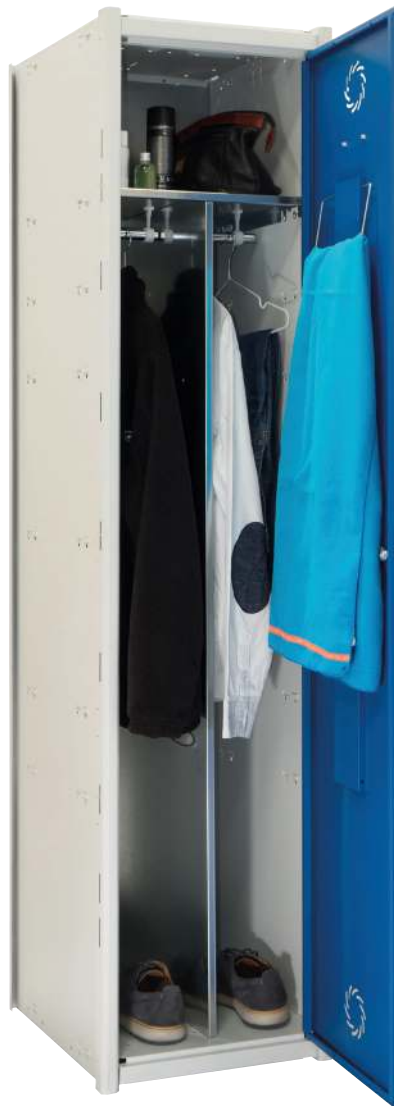

Interior **AV-40**

Divisoria opcional/Optional divider/
Séparation industrie salissante en
option/Divisor opcional

Opciones /Options/Options /Opções



Lateral embellecedor/Decorative end panel/
Enjoliveur latéral/Lateral de finição.



Sobretecho inclinado/Slope Top/Toit incliné/
Sobreteto com inclinação.



Altillo/Upper small joined locker/Casier en hauteur/
Pequeno cacifo para pôr encima do cacifo.



TAQUILLAS MODULARES

DISASSEMBLED LOCKERS / VESTIAIRES DEMONTABLES / ARMÁRIOS DE VESTIÁRIO DESMONTÁVEIS

SERIE AV



AV-25/1 COD: 32501 19,2kg · 0,26m ³	AV-25/2 COD: 32502 32,4kg · 0,49m ³	AV-25/3 COD: 32503 45,5kg · 0,72m ³	AV-25/4 COD: 32504 58,7kg · 0,95m ³	AV-30/1 COD: 33001 21,5kg · 0,30m ³	AV-30/2 COD: 33002 37,0kg · 0,58m ³	AV-30/3 COD: 33003 52,5kg · 0,85m ³	AV-30/4 COD: 33004 68,0kg · 1,13m ³	AV-35/1 COD: 33501 22,8kg · 0,35m ³	AV-35/2 COD: 33502 39,6kg · 0,67m ³	AV-35/3 COD: 33503 56,4kg · 0,99m ³	AV-40/1 COD: 61090 26,5kg · 0,39m ³	AV-40/2 COD: 61091 47,0kg · 0,76m ³	AV-40/3 COD: 61203 67,5kg · 1,13m ³	AV-45/1 COD: 61140 27,9kg · 0,44m ³	AV-45/2 COD: 61141 49,8kg · 0,85m ³
---	---	---	---	---	---	---	---	---	---	---	---	---	---	---	---

SERIE AT



AT-25/1 COD: 32511 19,9kg · 0,26m ³	AT-25/2 COD: 32512 33,8kg · 0,49m ³	AT-25/3 COD: 32513 47,7kg · 0,72m ³	AT-25/4 COD: 32514 61,6kg · 0,95m ³	AT-30/1 COD: 33011 21,1kg · 0,30m ³	AT-30/2 COD: 33012 36,2kg · 0,58m ³	AT-30/3 COD: 33013 51,3kg · 0,85m ³	AT-30/4 COD: 33014 66,4kg · 1,13m ³	AT-35/1 COD: 33511 22,7kg · 0,35m ³	AT-35/2 COD: 33512 39,4kg · 0,67m ³	AT-35/3 COD: 33513 56,1kg · 0,99m ³	AT-40/1 COD: 34011 25,0kg · 0,39m ³	AT-40/2 COD: 34012 44,0kg · 0,76m ³	AT-40/3 COD: 34013 63,0kg · 1,13m ³
---	---	---	---	---	---	---	---	---	---	---	---	---	---

SERIE AM



AM-25/1 COD: 32531 20,9kg · 0,26m ³	AM-25/2 COD: 32532 35,8kg · 0,49m ³	AM-25/3 COD: 32533 50,6kg · 0,72m ³	AM-25/4 COD: 32534 65,5kg · 0,95m ³	AM-30/1 COD: 33031 22,2kg · 0,30m ³	AM-30/2 COD: 33032 38,4kg · 0,58m ³	AM-30/3 COD: 33033 54,6kg · 0,85m ³	AM-30/4 COD: 33034 70,8kg · 1,13m ³	AM-35/1 COD: 33531 23,7kg · 0,35m ³	AM-35/2 COD: 33532 41,4kg · 0,67m ³	AM-35/3 COD: 33533 59,1kg · 0,99m ³	AM-40/1 COD: 34031 25,2kg · 0,39m ³	AM-40/2 COD: 34032 44,4kg · 0,76m ³	AM-40/3 COD: 34033 63,6kg · 1,13m ³
---	---	---	---	---	---	---	---	---	---	---	---	---	---

SERIE AC



AC-25/1 COD: 32521 21,8kg · 0,26m ³	AC-25/2 COD: 32522 37,6kg · 0,49m ³	AC-25/3 COD: 32523 53,4kg · 0,72m ³	AC-25/4 COD: 32524 69,2kg · 0,95m ³	AC-30/1 COD: 33021 23,3kg · 0,30m ³	AC-30/2 COD: 33022 40,7kg · 0,58m ³	AC-30/3 COD: 33023 58,0kg · 0,85m ³	AC-30/4 COD: 33024 75,4kg · 1,13m ³	AC-35/1 COD: 33521 25,08kg · 0,35m ³	AC-35/2 COD: 33522 44,16kg · 0,67m ³	AC-35/3 COD: 33523 63,24kg · 0,99m ³	AC-40/1 COD: 34021 26,7kg · 0,39m ³	AC-40/2 COD: 34022 47,4kg · 0,76m ³	AC-40/3 COD: 34023 68,1kg · 1,13m ³
---	---	---	---	---	---	---	---	--	--	--	---	---	---



SERIE AP

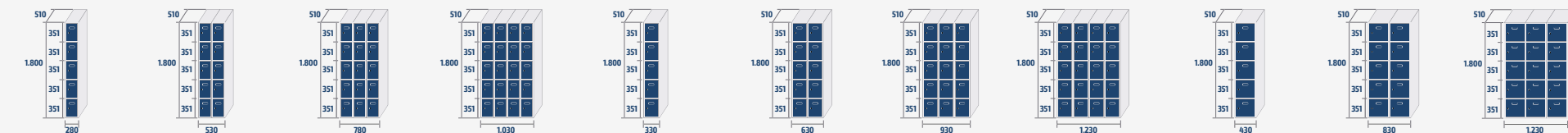

AP-25/1 COD: 32551 22,7kg · 0,26m ³	AP-25/2 COD: 32552 39,4kg · 0,49m ³	AP-25/3 COD: 32553 56,1kg · 0,72m ³	AP-25/4 COD: 32554 72,8kg · 0,95m ³	AP-30/1 COD: 33051 24,4kg · 0,30m ³	AP-30/2 COD: 33052 42,9kg · 0,58m ³	AP-30/3 COD: 33053 61,3kg · 0,85m ³	AP-30/4 COD: 33054 79,8kg · 1,13m ³	AP-40/1 COD: 34051 28,1kg · 0,39m ³	AP-40/2 COD: 34052 50,2kg · 0,76m ³	AP-40/3 COD: 34053 72,3kg · 1,13m ³
---	---	---	---	---	---	---	---	---	---	---

SERIE AB

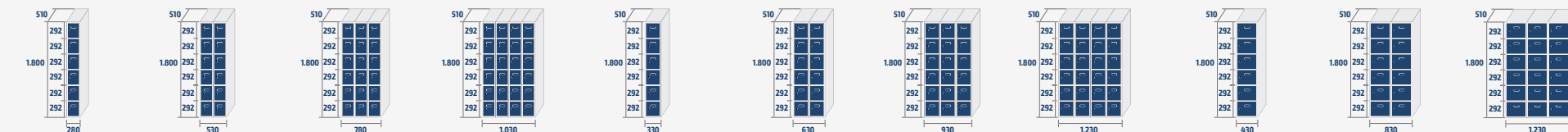

AB-25/1 COD: 32561 23,6kg · 0,26m ³	AB-25/2 COD: 32562 41,2kg · 0,49m ³	AB-25/3 COD: 32563 58,8kg · 0,72m ³	AB-25/4 COD: 32564 76,4kg · 0,95m ³	AB-30/1 COD: 33061 25,5kg · 0,30m ³	AB-30/2 COD: 33062 45,1kg · 0,58m ³	AB-30/3 COD: 33063 64,6kg · 0,85m ³	AB-30/4 COD: 33064 84,2kg · 1,13m ³	AB-40/1 COD: 34061 29,1kg · 0,39m ³	AB-40/2 COD: 34062 51,2kg · 0,76m ³	AB-40/3 COD: 34063 73,3kg · 1,13m ³
---	---	---	---	---	---	---	---	---	---	---

SERIE AZ

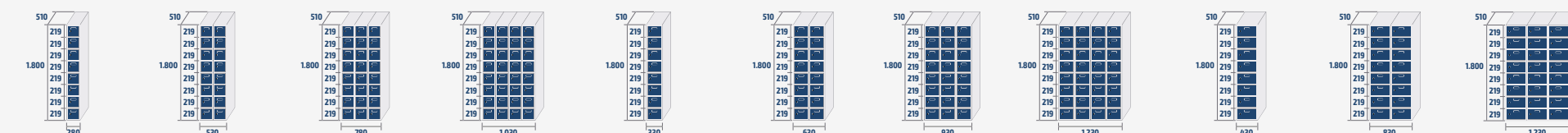

AZ-25/1 COD: 32581 25,4kg · 0,26m ³	AZ-25/2 COD: 32582 44,8kg · 0,49m ³	AZ-25/3 COD: 32583 64,2kg · 0,72m ³	AZ-25/4 COD: 32584 83,6kg · 0,95m ³	AZ-30/1 COD: 33081 27,7kg · 0,30m ³	AZ-30/2 COD: 33082 49,5kg · 0,58m ³	AZ-30/3 COD: 33083 71,2kg · 0,85m ³	AZ-30/4 COD: 33084 93kg · 1,13m ³	AZ-40/1 COD: 34081 31,9kg · 0,39m ³	AZ-40/2 COD: 34082 56,8kg · 0,76m ³	AZ-40/3 COD: 34083 81,7kg · 1,13m ³
---	---	---	---	---	---	---	---	---	---	---



TAQUILLAS MODULARES

DISASSEMBLED LOCKERS / VESTIAIRES DEMONTABLES / ARMÁRIOS DE VESTIÁRIO DESMONTÁVEIS

SERIE GYM

GYM SERIES / SÉRIE GYM / SÉRIE GYM



GYM-40/2



Doble fondo oculto/Covered double floor/
Double fond occulte/Fundo do cacifo oculto.



Interior GYM-35/3



CARACTERÍSTICAS BANCO / BENCH CHARACTERISTICS / CARACTERISTIQUES BANCS / CARACTERISTICAS BANCOS



Gran resistencia.
High resistance.
Très résistant.
Muito resistente.



Color standard: Gris RAL 7035.
Standard colour: Grey RAL 7035.
Couleur standard: Gris RAL 7035.
Cor standard: Cinza RAL 7035.



Microtexturado.
Microtextured.
Microtexturé.
Microtexturado.



Chasis en tubo de acero.
Steel tube chassis.
Structure en tube d'acier soudé.
Estrutura em tubo de aço soldado.

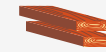

Listones de pino barnizado.
Varnished pine wood slats.
Assise en pin verni.
Assento de pinheiro envernizado.

OPCIONES BANCO / BENCH OPTIONS / OPTIONS BANCS / OPÇÕES BANCOS



Opción repisa zapatero.
Shoe rack option.
Option lattes repose-chaussures.
Opção sapateiro.



Estructura en acero inoxidable AISI 304.
Structure made of stainless steel AISI 304.
Structure en acier inoxydable AISI 304.
Estrutura em aço inox AISI 304.

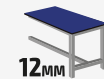

Tablero fenólico de 12 mm de espesor.
Seat made of HPL in 12 mm thickness
Assise en stratifié compact épaisseur 12 mm.
Assento em fenólico de 12 mm de espessura.

SERIE GYM

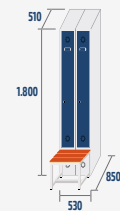

GYM-25/2
COD: 89252



GYM-25/3
COD: 89253

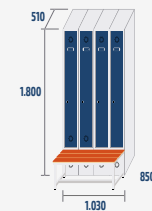

GYM-25/4
COD: 89254

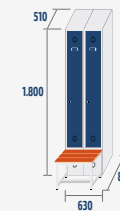

GYM-30/2
COD: 89302

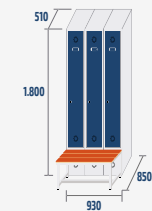

GYM-30/3
COD: 89303

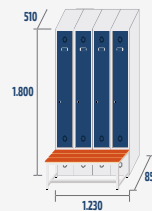

GYM-30/4
COD: 89304

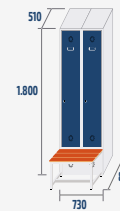

GYM-35/2
COD: 89352

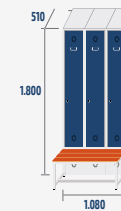

GYM-35/3
COD: 89353

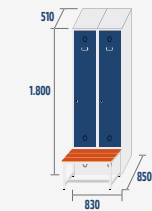

GYM-40/2
COD: 89402

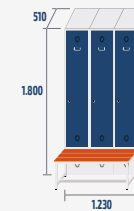

GYM-40/3
COD: 89403

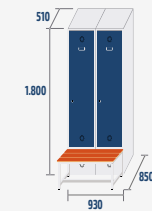

GYM-45/2
COD: 89452

SERIE CHASIS
CHASSIS SERIES / SÉRIE CHÂSSIS / SÉRIE CHASSIS

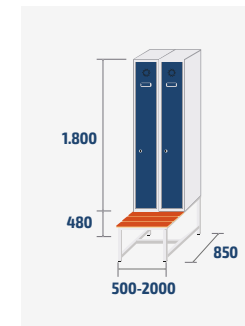

Combina con:
 Combines with:
 Combine avec:
 Combinado com:



TAQUILLAS ECO
ECO LOCKERS
VESTIAIRES ECO
CACIFOS ECO



TAQUILLAS MODULARES
DISASSEMBLED LOCKERS
VESTIAIRES DEMONTABLES
CACIFOS DESMONTÁVEIS



TAQUILLAS MONOBLOK
MONOBLOK LOCKERS
VESTIAIRES MONOBLOK
CACIFOS MONOBLOK

Opción/Option/Option/Opção



Banco retráctil / Retractable bench / Banc rétractable / Banco retrátil



TAQUILLAS MONOBLOK

MONOBLOK LOCKERS / VESTIAIRES MONOBLOK / CACIFOS MONOBLOK



SERIE SV

1 Puerta
Door
Porte
Porta



SERIE ST

2 Puertas
Doors
Portes
Portas



SERIE SM

3 Puertas
Doors
Portes
Portas



SERIE SC

4 Puertas
Doors
Portes
Portas



SERIE SP

5 Puertas
Doors
Portes
Portas



SERIE SB

6 Puertas
Doors
Portes
Portas



SERIE SZ

8 Puertas
Doors
Portes
Portas



SERIE SL2

2 Puertas en forma de L
L-shaped doors
Portes en forme de L
Portas em L





Interior **SV-40**

Divisoria opcional/Optional divider/
Séparation industrie salissante en
option/Divisor opcional



Interior **SV-30**



Interior **ST-30**



Interior **SL2-30**



TAQUILLAS MONOBLOK

MONOBLOK LOCKERS / VESTIAIRES MONOBLOK / CACIFOS MONOBLOK

SERIE SV

SV-25/1 COD: 42501 18,5kg · 0,24m ³	SV-25/2 COD: 42502 31kg · 0,48m ³	SV-25/3 COD: 42503 44,5kg · 0,71m ³	SV-25/4 COD: 42504 57kg · 0,95m ³	SV-30/1 COD: 43001 20,6kg · 0,29m ³	SV-30/2 COD: 43002 35,2kg · 0,57m ³	SV-30/3 COD: 43003 49,8kg · 0,86m ³	SV-30/4 COD: 43004 64,4kg · 1,14m ³	SV-40/1 COD: 71590 25kg · 0,38m ³	SV-40/2 COD: 71591 45kg · 0,76m ³	SV-40/3 COD: 71592 65kg · 1,14m ³	SV-50/1 COD: 71653 28kg · 0,48m ³	SV-50/2 COD: 71654 51kg · 0,95m ³

SERIE ST

ST-25/1 COD: 42511 18,4kg · 0,24m ³	ST-25/2 COD: 42512 30,8kg · 0,48m ³	ST-25/3 COD: 42513 44,2kg · 0,71m ³	ST-25/4 COD: 42514 56,6kg · 0,95m ³	ST-30/1 COD: 43011 19,8kg · 0,29m ³	ST-30/2 COD: 43012 33,6kg · 0,57m ³	ST-30/3 COD: 43013 47,4kg · 0,86m ³	ST-30/4 COD: 43014 62,2kg · 1,14m ³	ST-40/1 COD: 44011 23kg · 0,38m ³	ST-40/2 COD: 44012 41kg · 0,76m ³	ST-40/3 COD: 44013 59kg · 1,14m ³	ST-50/1 COD: 45011 26kg · 0,48m ³	ST-50/2 COD: 45012 47kg · 0,95m ³

SERIE SM

SM-25/1 COD: 42531 19,6kg · 0,24m ³	SM-25/2 COD: 42532 33,2kg · 0,48m ³	SM-25/3 COD: 42533 46,7kg · 0,71m ³	SM-25/4 COD: 42534 60,3kg · 0,95m ³	SM-30/1 COD: 43031 21kg · 0,29m ³	SM-30/2 COD: 43032 36kg · 0,57m ³	SM-30/3 COD: 43033 51kg · 0,86m ³	SM-30/4 COD: 43034 66kg · 1,14m ³	SM-40/1 COD: 44031 23,9kg · 0,38m ³	SM-40/2 COD: 44032 41,8kg · 0,76m ³	SM-40/3 COD: 44033 59,7kg · 1,14m ³	SM-50/1 COD: 45031 25,8kg · 0,48m ³	SM-50/2 COD: 45032 46,6kg · 0,95m ³

SERIE SC

SC-25/1 COD: 42521 20kg · 0,24m ³	SC-25/2 COD: 42522 34,2kg · 0,48m ³	SC-25/3 COD: 42523 48,8kg · 0,71m ³	SC-25/4 COD: 42524 63,4kg · 0,95m ³	SC-30/1 COD: 43021 21,5kg · 0,29m ³	SC-30/2 COD: 43022 37,1kg · 0,57m ³	SC-30/3 COD: 43023 53,1kg · 0,86m ³	SC-30/4 COD: 43024 69,2kg · 1,14m ³	SC-40/1 COD: 44021 25kg · 0,38m ³	SC-40/2 COD: 44022 44kg · 0,76m ³	SC-40/3 COD: 44023 63kg · 1,14m ³	SC-50/1 COD: 45021 27,8kg · 0,48m ³	SC-50/2 COD: 45022 49,6kg · 0,95m ³



SERIE SP



SP-25/1 COD: 42551 20,6kg · 0,24m ³	SP-25/2 COD: 42552 36,2kg · 0,48m ³	SP-25/3 COD: 42553 51,8kg · 0,71m ³	SP-25/4 COD: 42554 67,4kg · 0,95m ³	SP-30/1 COD: 43051 22kg · 0,29m ³	SP-30/2 COD: 43052 39,1kg · 0,57m ³	SP-30/3 COD: 43053 56,1kg · 0,86m ³	SP-30/4 COD: 43054 73,2kg · 1,14m ³	SP-40/1 COD: 44051 26kg · 0,38m ³	SP-40/2 COD: 44052 46kg · 0,76m ³	SP-40/3 COD: 44053 66kg · 1,14m ³	SP-50/1 COD: 45051 28,8kg · 0,48m ³	SP-50/2 COD: 45052 51,6kg · 0,95m ³
---	---	---	---	---	---	---	---	---	---	---	---	---

SERIE SB



SB-25/1 COD: 42561 21,6kg · 0,24m ³	SB-25/2 COD: 42562 38,2kg · 0,48m ³	SB-25/3 COD: 42563 54,8kg · 0,71m ³	SB-25/4 COD: 42564 71,4kg · 0,95m ³	SB-30/1 COD: 43061 23kg · 0,29m ³	SB-30/2 COD: 43062 41,1kg · 0,57m ³	SB-30/3 COD: 43063 59,1kg · 0,86m ³	SB-30/4 COD: 43064 72,2kg · 1,14m ³	SB-40/1 COD: 44061 27kg · 0,38m ³	SB-40/2 COD: 44062 48kg · 0,76m ³	SB-40/3 COD: 44063 69kg · 1,14m ³	SB-50/1 COD: 45061 29,8kg · 0,48m ³	SB-50/2 COD: 45062 53,6kg · 0,95m ³
---	---	---	---	---	---	---	---	---	---	---	---	---

SERIE SZ

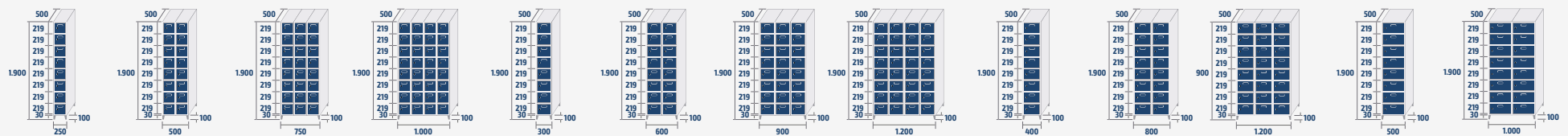

SZ-25/1 COD: 42581 23,6kg · 0,24m ³	SZ-25/2 COD: 42582 42,2kg · 0,48m ³	SZ-25/3 COD: 42583 60,8kg · 0,71m ³	SZ-25/4 COD: 42584 79,4kg · 0,95m ³	SZ-30/1 COD: 43081 25kg · 0,29m ³	SZ-30/2 COD: 43082 45,1kg · 0,57m ³	SZ-30/3 COD: 43083 65,1kg · 0,86m ³	SZ-30/4 COD: 43084 85,2kg · 1,14m ³	SZ-40/1 COD: 44081 29kg · 0,38m ³	SZ-40/2 COD: 44082 52kg · 0,76m ³	SZ-40/3 COD: 44083 75kg · 1,14m ³	SZ-50/1 COD: 45081 31,8kg · 0,48m ³	SZ-50/2 COD: 45082 57,6kg · 0,95m ³
---	---	---	---	---	---	---	---	---	---	---	---	---

SERIE SLZ

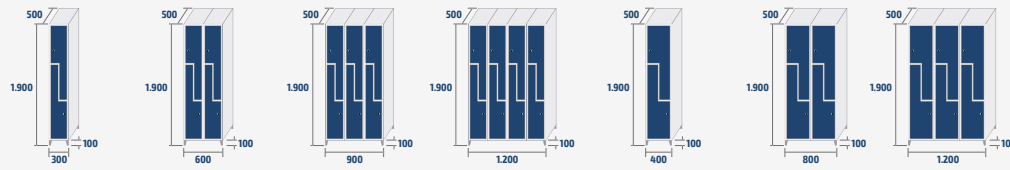

SLZ-30/1 COD: 43841 21kg · 0,29m ³	SLZ-30/2 COD: 43842 37,1kg · 0,57m ³	SLZ-30/3 COD: 43843 53,1kg · 0,86m ³	SLZ-30/4 COD: 43844 69,1kg · 1,14m ³	SLZ-40/1 COD: 43845 25kg · 0,38m ³	SLZ-40/2 COD: 43846 44kg · 0,76m ³	SLZ-40/3 COD: 43847 63kg · 1,14m ³
--	--	--	--	--	--	--



TAQUILLAS MONOBLOK PLUS **NEW**
MONOBLOK PLUS LOCKERS
VESTIAIRES **MONOBLOK PLUS**
CACIFOS **MONOBLOK PLUS**

CARACTERÍSTICAS / CHARACTERISTICS /
CARACTERISTIQUES / CHARACTERISTICAS

Estructura soldada.
Welded structure.
Structure soudée.
Estrutura soldada.

0,8mm

Espesores: Envolvente.
Thicknesses: Enveloping.
Épaisseurs: Enveloppe.
Espessura: Envelopagem.

Bisagra con freno.
Hinge with brake.
Charnière avec frein.
Dobradiça com freio.

Puerta a elegir (intercambiables) / Door to choose (interchangeable) /
Porte pour choisir (interchangeables) / Porta para escolher (intercambiável)

 Metálica tipo sandwich / Sandwich-type metal /
Métal type sandwich / Metal tipo sanduiche ▶ 19mm ◀

 Melamina / Melamine /
Mélamine / Melamina ▶ 19mm ◀

 Fenólico / HPL /
Stratifié / Resinas fenólicas ▶ 12mm ◀

COMBINACIONES Y MEDIDAS / COMBINATIONS AND DIMENSIONS /
COMBINAISONS ET MESURES / COMBINAÇÕES E MEDIDAS



SV-30/1 PLUS

Puerta fenólica / HPL door /
Porte stratifié / Porta resina fenólica



ST-30/1 PLUS

Puerta fenólica / HPL door /
Porte stratifié / Porta resina fenólica

CONSIGNA PLUS
LEFT-LUGGAGE LOCKER PLUS
CONSIGNE PLUS
CACIFO PLUS

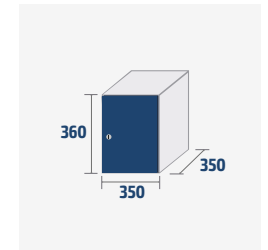

DEP351 PLUS

Puerta metálica / Metal door /
Porte métallique / Porta de metal



CONSIGNAS BAJO BANCO

LOCKERS FOR BENCH SEATS / CONSIGNES POUR BANCS / CACIFOS PARA BANCOS



BANCO / BENCH / BANC / BANCO
1.000 - 1.500 - 2.000 mm.



Lateral embellecedor
Decorative end panel
Enjoliveur lateral
Lateral de finishing



Consigna doble puerta
Double door locker
Consigne double porte
Cacifo porta dupla



Consigna
Single door locker
Consigne une porte
Cacifo única porta



SERIE CHASIS: 500-2.000 mm



Consigna
Locker
Consigne
Cacifo

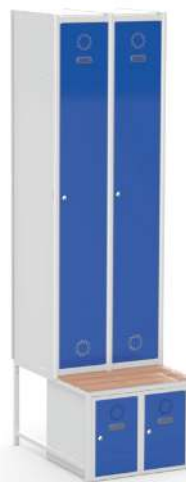

Lateral embellecedor
Decorative end panel
Enjoliveur lateral
Lateral de finishing



PERSONALIZACIÓN LUX

LUX PERSONALISATIONS / SUR MESURE LUX / CUSTOMIZADO LUX



Interior pintado.
Painted inside.
Intérieur peint.
Pintado Interior.



Espejo.
Mirror.
Miroir.
Espelho.



Tirador y llave abisagrada.
Handle and hinged key.
Poignée et clé pliante.
Puxador e chave articulada.



Conteras de plástico.
Plastic caps.
Capuchons en plastique.
Tampões de plástico.

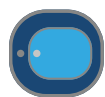

TAQUILLAS MULTIPUERTAS

MULTIDOOR LOCKERS / CASIERS VISITABLES / CACIFOS MULTIPORTAS



SERIE STV2

2 Puertas
Doors
Portes
Portas



SERIE STV3

3 Puertas
Doors
Portes
Portas



SERIE STV4

4 Puertas
Doors
Portes
Portas



SERIE STV5

5 Puertas
Doors
Portes
Portas



SERIE STV6

6 Puertas
Doors
Portes
Portas



SERIE STV8

8 Puertas
Doors
Portes
Portas



STV4-40/2



STV8-40/1



SERIE STV2

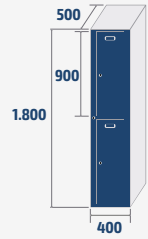

STV2-40/1
COD: 44821
25kg · 0,29m³

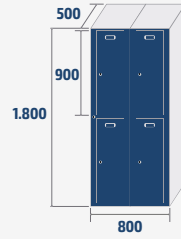

STV2-40/2
COD: 44822
45kg · 0,57m³

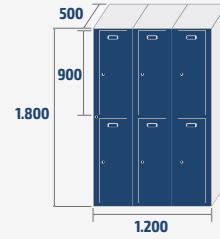

STV2-40/3
COD: 44823
65kg · 1,08m³

SERIE STV3

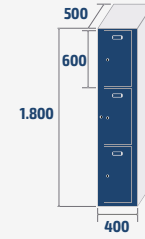

STV3-40/1
COD: 44831
25,9kg · 0,29m³



STV3-40/2
COD: 44832
45,8kg · 0,57m³



STV3-40/3
COD: 44833
65,7kg · 1,08m³

SERIE STV4

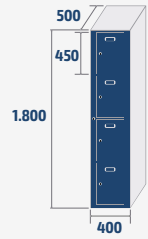

STV4-40/1
COD: 44841
28kg · 0,29m³

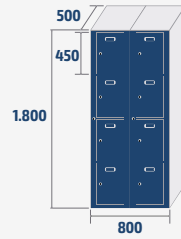

STV4-40/2
COD: 44842
50kg · 0,57m³

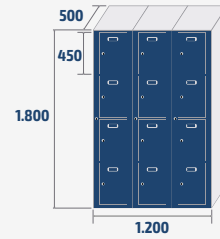

STV4-40/3
COD: 44843
69kg · 1,08m³

SERIE STV5

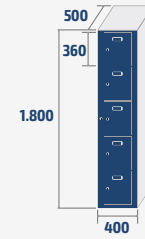

STV5-40/1
COD: 44851
29kg · 0,29m³



STV5-40/2
COD: 44852
52kg · 0,57m³



STV5-40/3
COD: 44853
72kg · 1,08m³

SERIE STV6

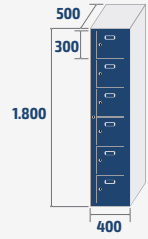

STV6-40/1
COD: 44861
30kg · 0,29m³

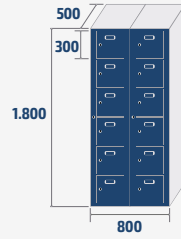

STV6-40/2
COD: 44862
54kg · 0,57m³

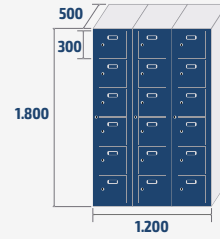

STV6-40/3
COD: 44863
78kg · 1,08m³

SERIE STV8

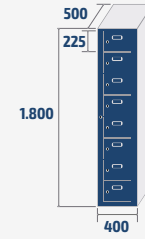

STV8-40/1
COD: 44881
31kg · 0,29m³

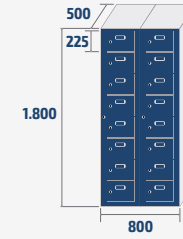

STV8-40/2
COD: 44882
56kg · 0,57m³

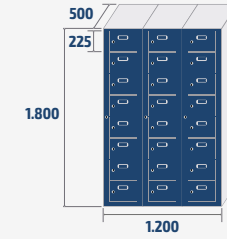

STV8-40/3
COD: 44883
81kg · 1,08m³

CARACTERÍSTICAS
CHARACTERISTICS
CARACTERISTIQUES
CARACTERÍSTICAS

Espesores/Thicknesses/Épaisseurs/Espessura.

Envolvente

Enveloping/Enveloppe/Envelopagem

0,6mm

Marco de puertas

Doors frame/Cadre de portes/Armação de portas

1mm

Puertas

Doors/Portes/Portas

0,8mm







TAQUILLAS INOX
INOX LOCKERS / VESTIAIRES INOX / ARMÁRIOS DE VESTIÁRIO INOX





CARACTERÍSTICAS / CHARACTERISTICS / CARACTERISTIQUES / CARACTERISTICAS

 <p>Etiquetero y rosetas de ventilación. Card holder and vent system. Porte-étiquette et volets d'aération. Placa de numeração e ventilação.</p>	 <p>Estructura soldada. Welded structure. Structure soudée. Estrutura soldada.</p>	 <p>Sobretecho inclinado. Slope Top. Toit incliné. Sobreteto com inclinação.</p>	 <p>Cerradura de llave. Standard key lock. Serrure standard à clé. Fechadura standard de chave.</p>	 <p>Pata regulable en altura. Legs adjustable in height. Pieds réglables en hauteur. Pés reguláveis em altura.</p>
 <p>Sin montaje. Without assembly. Sans montage. Sem montagem.</p>	 <p>Inox. Stainless steel. Inox. Inox.</p>	 <p>Puerta con refuerzo longitudinal. Door with longitudinal reinforcement. Porte avec renfort longitudinal. Porta com reforço longitudinal.</p>	 <p>Espesores. Thicknesses. Épaisseurs. Espessura.</p>	 <p>Recomendado para ambientes húmedos. Resistente al agua. Recommended for wet areas. Waterproof. Récommandé pour les environnements humides. Recomendado para lugares com humidade. Resistente al água.</p>

2

SISTEMAS DE APERTURA / OPENING SYSTEM / SYSTÈMES D'OUVERTURE / SISTEMA DE ABERTURA

 <p>Pomo en poliamida. Padlockable polyamide Lock. Poignée en polyamide. Fechadura de cadeado em poliamida.</p>	 <p>Cerradura de combinación y llave de emergencia. Manual combination lock with emergency key. Serrure à combinaison de 4 chiffres et clé de secours. Fechadura de combinação e chave de emergência.</p>	 <p>Cerraduras de proximidad. RFID Locks. Serrures de proximité. Fechaduras de proximidade.</p>
 <p>Monedero con moneda retornable/con cajetín depósito. Coin-operated Lock with coin-return/collect box. Monnayeur avec monnaie retournable/tirelire. Moedeiro moeda retornável/caixinha.</p>	 <p>Cerraduras electrónicas de combinación de 4 dígitos. Electronic combination locks of 4 digits. Serrures électroniques à combinaison de 4 chiffres. Fechaduras electrónicas, combinação de 4 dígitos.</p>	



SERIE SV

1 Puerta
Door
Porte
Porta



SERIE ST

2 Puertas
Doors
Portes
Portas

OPCIONES / OPTIONS / OPTIONS / OPÇÕES



Divisoria en Serie V-40.
Divider in V-40 series.
Séparation industrie salissante dans la Série V-40.
Divisor na Série V-40.



Opción de fabricación de 3, 4, 5, 6, 8 puertas por columna.
Manufacturing option of 3, 4, 5, 6, 8 doors per column.
Option de fabrication 3, 4, 5, 6, 8 portes par colonne.
Opção de fabricação 3, 4, 5, 6, 8 portas por coluna.



TAQUILLAS INOX

INOX LOCKERS / VESTIAIRES INOX / ARMÁRIOS DE VESTIÁRIO INOX



Interior **SERIE ST INOX**



Interior **SERIE ST INOX**



**Sobretecho inclinado/Slope Top/Toit incliné/
Sobreteto com inclinação.**



SERIE SV

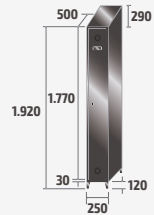

SV-25/1 INOX
 COD: 82901
24,6kg · 0,24m³

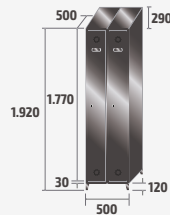

SV-25/2 INOX
 COD: 82902
40,3kg · 0,48m³

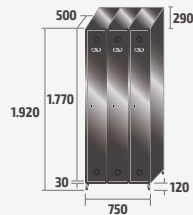

SV-25/3 INOX
 COD: 82903
57,8kg · 0,71m³

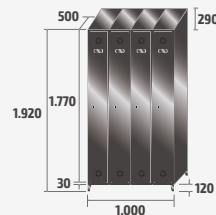

SV-25/4 INOX
 COD: 82904
74,1kg · 0,95m³

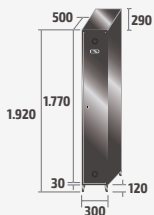

SV-30/1 INOX
 COD: 83901
31kg · 0,38m³

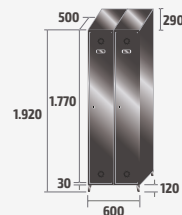

SV-30/2 INOX
 COD: 83902
49kg · 0,69m³

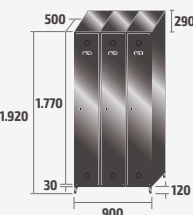

SV-30/3 INOX
 COD: 83903
67kg · 0,99m³

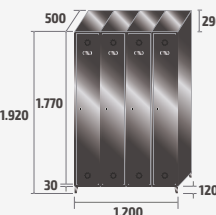

SV-30/4 INOX
 COD: 83904
85kg · 1,31m³

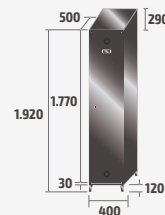

SV-40/1 INOX
 COD: 84901
36kg · 0,38m³

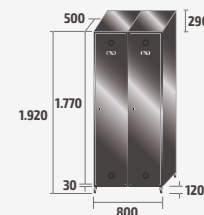

SV-40/2 INOX
 COD: 84902
59kg · 0,76m³

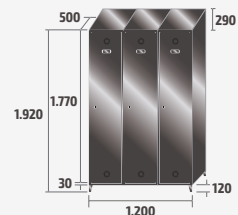

SV-40/3 INOX
 COD: 84903
82kg · 1,14m³

SERIE ST

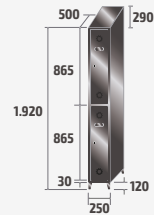

ST-25/1 INOX
 COD: 82911
25,6kg · 0,24m³

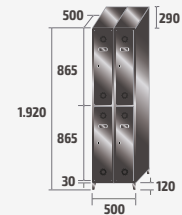

ST-25/2 INOX
 COD: 82912
41,3kg · 0,48m³

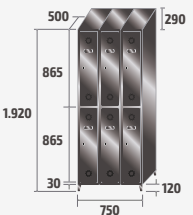

ST-25/3 INOX
 COD: 82913
58,8kg · 0,71m³

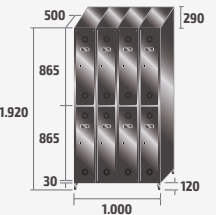

ST-25/4 INOX
 COD: 82914
75,1kg · 0,95m³

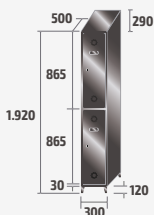

ST-30/1 INOX
 COD: 83911
32kg · 0,38m³

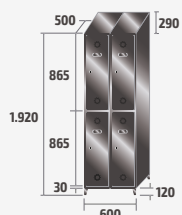

ST-30/2 INOX
 COD: 83912
50kg · 0,69m³

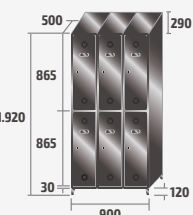

ST-30/3 INOX
 COD: 83913
68kg · 0,99m³

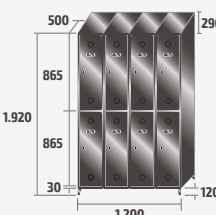

ST-30/4 INOX
 COD: 83914
86kg · 1,31m³

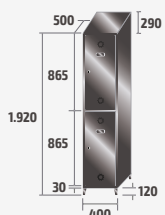

ST-40/1 INOX
 COD: 84911
37kg · 0,38m³

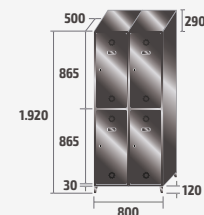

ST-40/2 INOX
 COD: 84912
60kg · 0,76m³

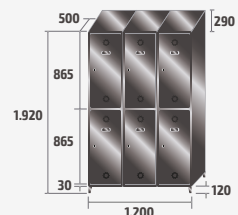

ST-40/3 INOX
 COD: 84913
83kg · 1,14m³



DIMENSIONES ESPECIALES SPECIALS DIMENSIONS DIMENSIONS SPÉCIALES DIMENSIÕES ESPECIAIS



DISTRIBUCIONES INTERIORES INTERNAL DISTRIBUTIONS DISTRIBUTIONS INTERNES DISTRIBUÇÕES INTERIORES



Cambio de sentido apertura de puertas.
Change of door opening directions.
Change de sens d'ouverture des portes.
Possível mudar o lado de abertura das portas.





PUERTAS METÁLICAS CON ENREJILLADO
STEEL DOORS WITH MESH-GRILLE
PORTES MÉTALLIQUES AVEC GRILLAGE
PORTAS DE AÇO COM GRELHA



PUERTAS DE METACRILATO
METHACRYLATE DOORS
PORTES EN MÉTHACRYLATE
PORTAS METACRILATO





TAQUILLA LAVANDERÍA **NEW**
LAUNDRY BULK COLLECTOR LOCKER
ARMOIRE A LINGE
CACIFO LAVANDERIA

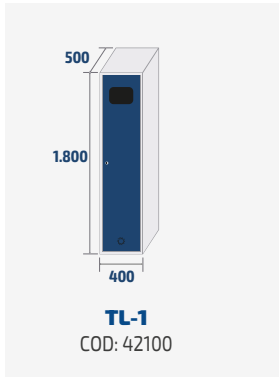

0,8mm
Espesores.
 Thicknesses.
 Épaisseurs.
 Espessura.



ARMARIO MATERIAL DE LIMPIEZA
CLEANING MATERIAL LOCKER
ARMOIRE POUR MATERIEL DE NETTOYAGE
ARMARIO DE LIMPIEZA

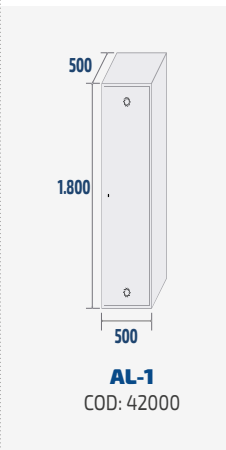

0,8mm
Espesores.
 Thicknesses.
 Épaisseurs.
 Espessura.

SERIE SAC **NEW**

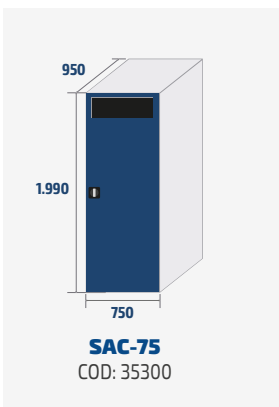

1,5mm
Espesores.
 Thicknesses.
 Épaisseurs.
 Espessura.



Cerradura de llave.
 Standard key lock.
 Serrure standard à clé.
 Fechadura standard de chave.



Estructura soldada.
 Welded structure.
 Structure soudée.
 Estrutura soldada.



Sin montaje.
 Without assembly.
 Sans montage.
 Sem montagem.



Estructura soldada.
 Welded structure.
 Structure soudée.
 Estrutura soldada.



Sin montaje.
 Without assembly.
 Sans montage.
 Sem montagem.



MICRO TEX
Microtexturado.
 Microtextured.
 Microtexturé.
 Microtexturado.



Cerradura de llave.
 Standard key lock.
 Serrure standard à clé.
 Fechadura standard de chave.

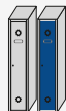

Corpo gris y puertas azul o gris.
 Grey body and blue or grey doors.
 Corp gris et portes bleu ou gris.
 Corpo cinza e portas azuis ou cinza.



EPOXI
Pintado en Epoxi.
 Painted in Epoxy.
 Peinture en epoxi.
 Pintura em epoxi.



MICRO TEX
Microtexturado.
 Microtextured.
 Microtexturé.
 Microtexturado.



Color estándar: gris RAL 7035.
 Standard colour: grey RAL 7035.
 Couleur standard: gris RAL 7035.
 Cor standard: cinza RAL 7035.



EPOXI
Pintado en Epoxi.
 Painted in Epoxy.
 Peinture en epoxi.
 Pintura em epoxi.



Barra portaperchas.
 Coat rod.
 Tringle porte cintres.
 Barra para pendurar cabides.

RAL 7035 RAL 5010

RAL 7035



SKI-1



SKI-2



CARACTERÍSTICAS / CHARACTERISTICS / CARACTERISTIQUES / CARACTERISTICAS



Estructura soldada.
Welded structure.
Structure soudée.
Estrutura soldada.



Sin montaje.
Without assembly.
Sans montage.
Sem montagem.

GALVA

Acero galvanizado.
Galvanized steel.
Acier galvanisée.
Aço galvanizado.

**OPCIONES / OPTIONS
OPTIONS / OPÇÕES**



Opción calefactable.
Heating option.
Option chauffante.
Opção calentador.



BLANCO-1

Color estándar: blanco RAL 9010.
Standard colour: white RAL 9010.
Couleur standard: blanc RAL 9010.
Cor standard: branco RAL 9010.

EPOXI

Pintado en Epoxi.
Painted in Epoxy.
Peinture en epoxi.
Pintura em epoxi.



Cerradura de falleba.
Lock of shutter-bolt.
Serrure d'espagnolette.
Fechadura de espagnolette.



Puerta con refuerzo longitudinal.
Door with longitudinal reinforcement.
Porte avec renfort longitudinal.
Porta com reforço longitudinal.

**MICRO
TEX**

Microtexturado.
Microtextured.
Microtexturé.
Microtexturado.



Suelo perforado.
Perforated bottom.
Plancher perforé.
Piso perforado.



Espesores.
Thicknesses.
Épaisseurs.
Espessura.

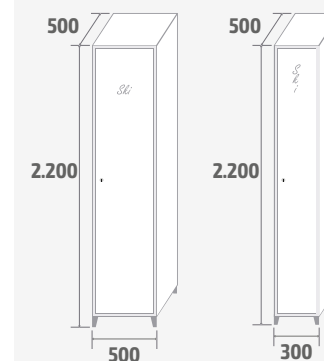

SKI-1
COD: 42500
44kg · 0,55m³

SKI-2
COD: 42530
31kg · 0,33m³



CONSIGNAS

LEFT-LUGGAGE LOCKERS / CONSIGNES / CACIFOS



SERIE **BANCO**



SERIE **MINI**



SERIE **SUPERMERCADO VERTICAL**



SERIE **SUPERMERCADO METACRILATO** 



SERIE **MARCO AMARRE**



SERIE **MONOBLOK METACRILATO** 



SERIE **GOLF** 



SERIE **MALETAS** 



SERIE **350**



SERIE **MINIBOX**



SERIE **LOCKER**



SERIE **CAS**



SERIE **CB11** 





CARACTERÍSTICAS / CHARACTERISTICS / CARACTERISTIQUES / CARACTERISTICAS



RAL 7035

Estándar: Gris RAL 7035.
Standard: Grey RAL 7035.
Standard: Gris RAL 7035.
Padrão: Cinza RAL 7035.



Metal.
Metal.
Metal.
Metal.



Gran resistencia.
High resistance.
Très résistant.
Muito resistente.



Cerradura de llave.
Standard key lock.
Serrure standard à clé.
Fechadura standard de chave.



Espesores.
Thicknesses.
Épaisseurs.
Espessura.



Etiquetero y rosetas de ventilación.
Card holder and vent system.
Porte-étiquette et volets d'aération.
Placa de numeração e ventilação.

EPOXI

Pintado en Epoxi.
Painted in epoxy.
Peinture en epoxi.
Pintura em epoxi.



No es recomendable para espacios húmedos.
Not recommended for wet spaces.
Pas recommandé pour les environnements humides.
Nao é recomendável para lugares com humidade.

**MICRO
TEX**

Microtexturado.
Microtextured.
Microtexturé.
Microtexturado.

OPCIONES / OPTIONS / OPTIONS / OPÇÕES



Ranura buzón.
Mailbox Slot.
Fente boîte aux lettres.
Obertura para cartas.



Espejo.
Mirror.
Miroir.
Espelho.



Placa de numeración.
Numeration plate.
Plaque de numérotation.
Placa de numeração.



Pulsera de nylon.
Nylon bracelet.
Bracelet en nylon.
Pulseira de náilon.



Pulsera elástica.
Elastic Bracelet.
Bracelet élastique.
Pulseira elástica.



Pintura antibacteriana.
Antibacterial paint.
Peinture antibactérienne.
Tinta antibacteriana.

SISTEMAS DE APERTURA / OPENING SYSTEM / SYSTÈMES D'OUVERTURE / SISTEMA DE ABERTURA

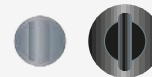

Pomo en poliamida / metálico.
Padlockable polyamide Lock / metallic Lock.
Serrure à porte cadenas en polyamide / métallique.
Fechadura de cadeado em poliamida / metal.



Cerradura de combinación y llave de emergencia.
Manual combination lock with emergency key.
Serrure à combinaison de 4 chiffres et clé de secours.
Fechadura de combinação e chave de emergência.



Tirador metálico.
Metal handle.
Poignée en métal.
Cabo de metal.



Imán.
Magnet.
Aimant.
Magnético.



Monedero con moneda retornable/con cajetín depósito.
Coin-operated Lock with coin-return/collect box.
Monnayeur avec monnaie retournable/tirelire.
Moedeiro moeda retornável/caixinha.



Cerraduras electrónicas de combinación de 4 dígitos.
Electronic combination locks of 4 digits.
Serrures électroniques à combinaison de 4 chiffres.
Fechaduras electrónicas, combinação de 4 dígitos.



Cerraduras de proximidad.
RFID Locks.
Serrures de proximité.
Fechaduras de proximidade.

COLORES OPCIONALES PUERTAS Y CUERPO / OPTIONAL DOOR AND BODY COLOURS / COULEURS OPTIONNELS POUR CORPS ET PORTES / CORES DE PORTAS E CORPO OPCIONAIS



RAL 9010 RAL 9001 RAL 1017 RAL 1021 RAL 2004 RAL 4010 RAL 3017 RAL 3000 RAL 3005 RAL 4005 RAL 6029 RAL 6034 RAL 5015 RAL 5023 RAL 5010 RAL 8025 RAL 7035 RAL 9006 RAL 7036 RAL 7016 RAL 9005



CONSIGNAS

LEFT-LUGGAGE LOCKERS / CONSIGNES / CACIFOS

SERIE BANCO BANCO SERIES SÉRIE BANCO SÉRIE BANCO



Idóneo para objetos personales.
Ideal for personal items.
Convient aux objets personnels.
Adequado para itens pessoais.

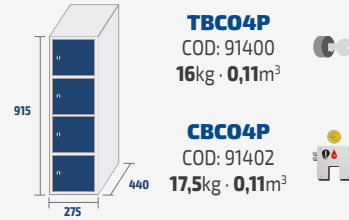

SERIE MINI MINI SERIES SÉRIE MINI SÉRIE MINI



Idóneo para objetos personales.
Ideal for personal items.
Convient aux objets personnels.
Adequado para itens pessoais.

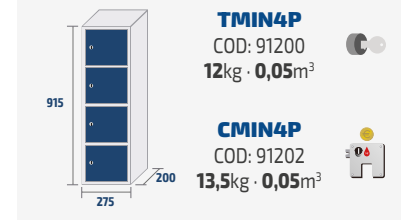

SERIE SUPERMERCADO VERTICAL SUPERMERCADO VERTICAL SERIES SÉRIE SUPERMERCADO VERTICAL SÉRIE SUPERMERCADO VERTICAL



Idóneo para supermercados.
Ideal for supermarkets.
Idéal pour les supermarchés.
Ideal para supermercados.

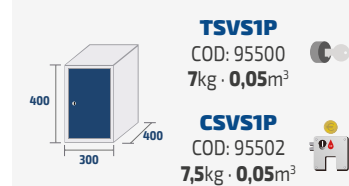
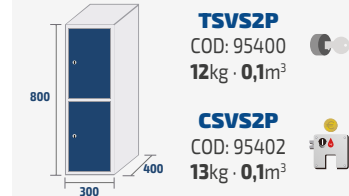
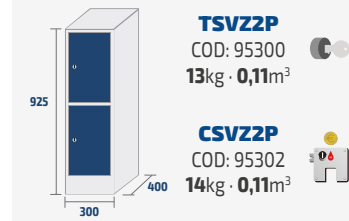

SERIE SUPERMERCADO METACRILATO SUPERMERCADO METACRILATO SERIES SÉRIE SUPERMERCADO METACRILATO SÉRIE SUPERMERCADO METACRILATO



Idóneo para supermercados.
Ideal for supermarkets.
Idéal pour les supermarchés.
Ideal para supermercados.

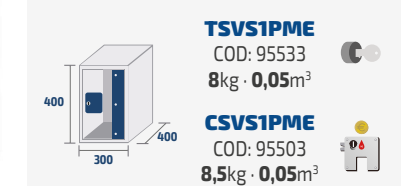
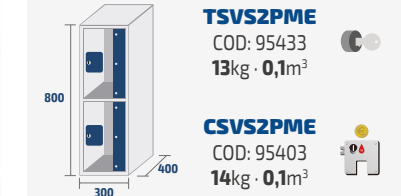
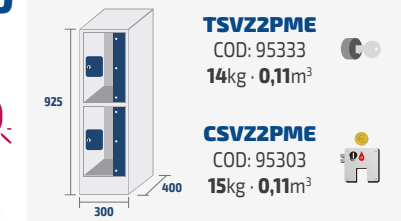

SERIE MARCO AMARRE
MARCO AMARRE SERIES
SÉRIE MARCO AMARRE
SÉRIE MARCO AMARRE



Idóneo para supermercados.
 Ideal for supermarkets.
 Idéal pour les supermarchés.
 Ideal para supermercados.



CONSIGNAS
LEFT-LUGGAGE LOCKERS / CONSIGNES / CACIFOS

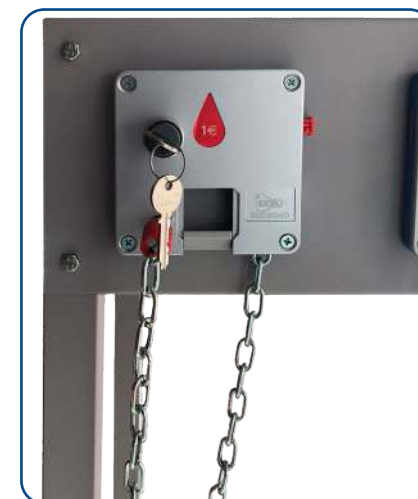

	<p>MA900 COD: 90222 18,5kg · 0,08m³ 5 Monederos. Coin-operated Locks. Monnayeurs. Moedeiros.</p>
	<p>MA1200 COD: 90322 21kg · 0,09m³ 6 Monederos. Coin-operated Locks. Monnayeurs. Monedeiros.</p>
	<p>MA1500 COD: 90422 23,5kg · 0,10m³ 8 Monederos. Coin-operated Locks. Monnayeurs. Monedeiros.</p>

* Compatible with SERIE SUPERMERCADO VERTICAL y SERIE SUPERMERCADO METACRILATO
 * Compatible with SUPERMERCADO VERTICAL and SUPERMERCADO METACRILATO SERIES.
 * Compatible avec SÉRIE SUPERMERCADO VERTICAL et SÉRIE SUPERMERCADO METACRILATO.
 * Compatível com SÉRIE SUPERMERCADO VERTICAL y SÉRIE SUPERMERCADO METACRILATO.





SERIE MONOBLOK METACRILATO 
MONOBLOK METACRILATO SERIES
SÉRIE MONOBLOK METACRILATO
SÉRIE MONOBLOK METACRILATO



Idóneo para supermercados.
 Ideal for supermarkets.
 Idéal pour les supermarchés.
 Ideal para supermercados.

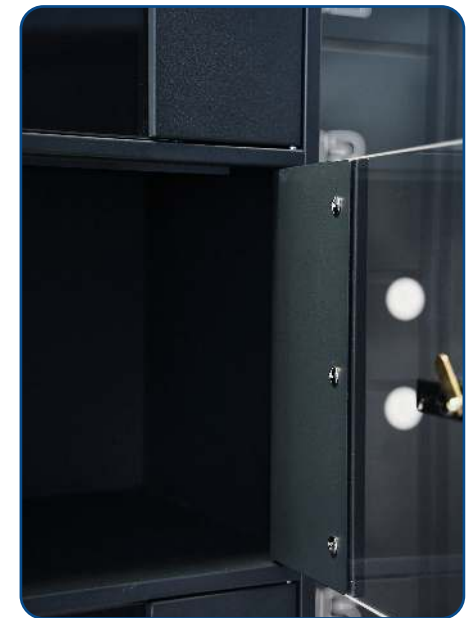

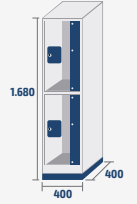
									
CM2P1200-S COD: 42802 22kg · 0,19m ³	CM3P1200-S COD: 42803 24kg · 0,19m ³	CM2P1600-S COD: 42902 25kg · 0,26m ³	CM3P1600-S COD: 42904 26kg · 0,26m ³	CM4P1600-S COD: 42913 28kg · 0,26m ³	CM2P1200-D COD: 42812 44kg · 0,38m ³	CM3P1200-D COD: 42813 48kg · 0,38m ³	CM2P1600-D COD: 42903 50kg · 0,51m ³	CM3P1600-D COD: 42912 53kg · 0,51m ³	CM4P1600-D COD: 42914 55kg · 0,51m ³



SERIE GOLF NEW

GOLF SERIES
SÉRIE GOLF
SÉRIE GOLF



Golf.
Golf.
Golf.
Golf.

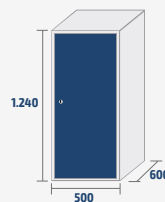

TGOLF1P
COD: 99600
21kg · 0,37m³



CGOLF1P
COD: 99500
22kg · 0,37m³



SERIE MALETAS NEW

MALETAS SERIES
SÉRIE MALETAS
SÉRIE MALETAS



Maletas.
Suitcases.
Valises.
Malas de viagem.



Espesores.
Thicknesses.
Épaisseurs.
Espessura.

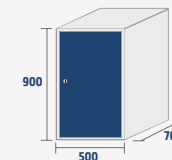

CMAL1P
COD: 97500
39kg · 0,31m³



OPCIONES / OPTIONS / OPTIONS / OPÇÕES

HPL

Fenólico.
HPL.
Stratifié compact.
Resinas fenólicas.

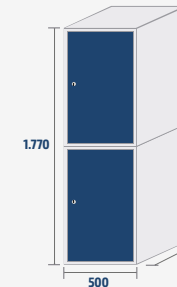

CMAL2P
COD: 40275

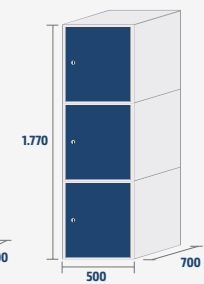

CMAL3P
COD: 40276



CONSIGNAS

LEFT-LUGGAGE LOCKERS / CONSIGNES / CACIFOS

SERIE 350 350 SERIES SÉRIE 350 SÉRIE 350



CON351

DEP352

CON353



OPCIONES / OPTIONS / OPTIONS / OPÇÕES



Sobretecho.

Slope top.
Toit incliné.
Sobreteito com pequena inclinação.



Zócalo.

Base.
Socle.
Soclo.

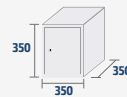

DEP351

COD: 35010
7kg · 0,04m³



CON351

COD: 35011
8kg · 0,04m³



DEP352

COD: 35020
14kg · 0,09m³



CON352

COD: 35021
16kg · 0,09m³

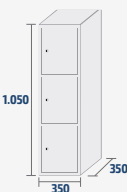

DEP353

COD: 35030
21kg · 0,13m³



CON353

COD: 35031
22kg · 0,13m³



SERIE MINISP MINISP SERIES SÉRIE MINISP SÉRIE MINISP



MINISP



Cerradura de combinación y llave de emergencia.
Manual combination lock with emergency key.
Serrure à combinaison de 4 chiffres et clé de secours.
Fechadura de combinação e chave de emergência.

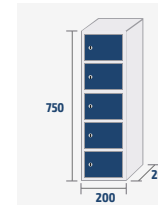

MINISP

COD: 91000
9kg · 0,03m³



SERIE LOCKER LOCKER SERIES SÉRIE LOCKER SÉRIE LOCKER



LOC300

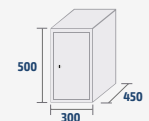

LOC300

COD: 30010
8kg · 0,07m³



SERIE MINIBOX
MINIBOX SERIES
SÉRIE MINIBOX
SÉRIE MINIBOX



BOX8P

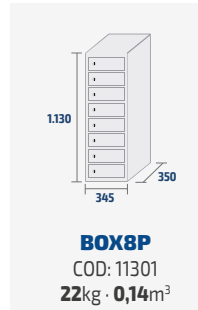

SERIE CAS400
CAS400 SERIES
SÉRIE CAS400
SÉRIE CAS400



CAS431



CAS432



CAS433

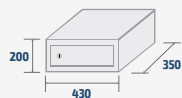

CAS431
 COD: 35431
 4kg · 0,031m³

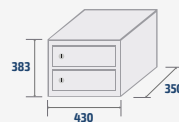

CAS432
 COD: 35432
 7kg · 0,058m³

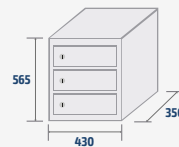

CAS433
 COD: 35433
 10kg · 0,085m³

SERIE CB11 
CB11 SERIES
SÉRIE CB11
SÉRIE CB11

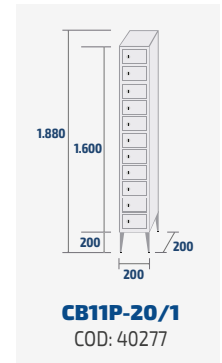

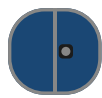

ARMARIOS DE OFICINA Y TALLER

OFFICE AND INDUSTRIAL CABINETS / ARMOIRES DE BUREAU ET ATELIER / ARMÁRIOS DE ESCRITORIO

CARACTERÍSTICAS / CHARACTERISTICS / CARACTERISTIQUES / CARACTERISTICAS



Estándar: Gris RAL 7035.
Standard: Grey RAL 7035.
Standard: Gris RAL 7035.
Padrão: Cinza RAL 7035.

RAL 7035



Metal.
Metal.
Metal.
Metal.



Gran resistencia.
High resistance.
Très résistant.
Muito resistente.

EPOXI

Pintado en Epoxi.
Painted in Epoxy.
Peinture en epoxi.
Pintura em epoxi.



Estructura soldada.
Welded structure.
Structure soudée.
Estrutura soldada.

**MICRO
TEX**

Microtexturado.
Microtextured.
Microtexturé.
Microtexturado.



Cerradura de falleba.
Lock of shutter-bolt.
Serrure d'espagnolette.
Fechadura de espagnolette.



ARM05



ARM01

OPCIONES / OPTIONS / OPTIONS / OPÇÕES



Bandeajs adicionales.
Additional sheets.
Étagères supplémentaires.
Prateleiras adicionais.

INOX

Acero inoxidable.
Stainless steel.
Acier inoxydable.
Aço inoxidável.



Desmontable.
Disassembled.
Démontable.
Desmontável.



COLORES OPCIONALES PUERTAS Y CUERPO / OPTIONAL DOOR AND BODY COLOURS / COULEURS OPTIONNELS POUR CORPS ET PORTES / CORES DE PORTAS E CORPO OPCIONAIS



RAL 9010	RAL 9001	RAL 1017	RAL 1021	RAL 2004	RAL 4010	RAL 3017	RAL 3000	RAL 3005	RAL 4005	RAL 6029	RAL 6034	RAL 5015	RAL 5023	RAL 5010	RAL 8025	RAL 7035	RAL 9006	RAL 7036	RAL 7016	RAL 9005
----------	----------	----------	----------	----------	----------	----------	----------	----------	----------	----------	----------	----------	----------	----------	----------	----------	----------	----------	----------	----------

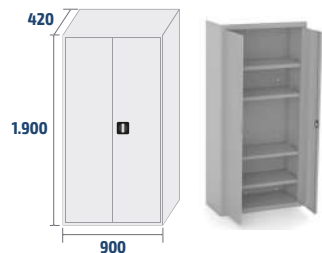

ARM01
 COD: 19001



ARM02
 COD: 19002



ARM03
 COD: 19003

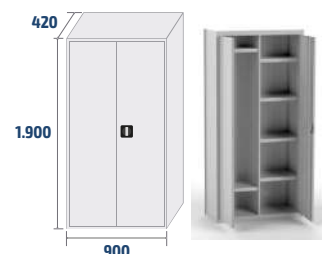

ARM04
 COD: 19004

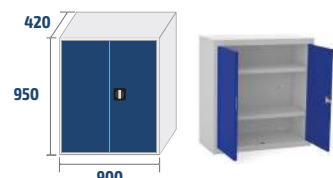

ARM05
 COD: 90001

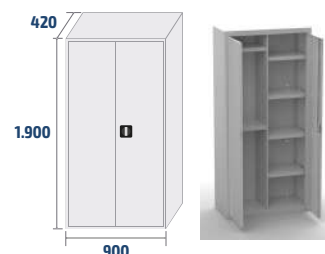

ARM06
 COD: 19006



ARM07
 COD: 19007



ARM08
 COD: 19008

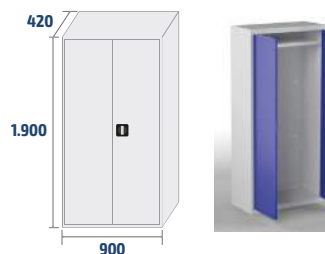

ARM09
 COD: 19009



ARM01



3

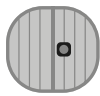

ARMARIO METÁLICO DE PERSIANA PVC

METAL CABINET WITH PVC ROLLING DOOR / ARMOAIRE MÉTALLIQUE A RIDEAU PVC / ARMÁRIOS DE ESCRITORIO E PVC

CARACTERÍSTICAS / CHARACTERISTICS / CARACTERISTIQUES / CARACTERISTICAS



Estándar: Gris RAL 7035.
Standard: Grey RAL 7035.
Standard: Gris RAL 7035.
Padrão: Cinza RAL 7035.

RAL 7035



Metal.
Metal.
Metal.
Metal.



Gran resistencia.
High resistance.
Très résistant.
Muito resistente.

EPOXI

Pintado en Epoxi.
Painted in Epoxy.
Peinture en epoxi.
Pintura em epoxi.



Estructura soldada.
Welded structure.
Structure soudée.
Estrutura soldada.

**MICRO
TEX**

Microtexturado.
Microtextured.
Microtexturé.
Microtexturado.



Cerradura de llave.
Standard key lock.
Serrure standard à clé.
Fechadura standard de chave.



Tirador embutido.
Recessed handle.
Poignée encastrée.
Puxador embutido.



Regulación en altura.
Height adjustment.
Réglage en hauteur.
Ajuste de altura.



ARMP-07/1



ARMP-16/2



PERSIANA / ROLLING DOOR / RIDEAU / ROLO CEGO



RAL 7035.
RAL 7035.
RAL 7035.
RAL 7035.



RAL 9006.
RAL 9006.
RAL 9006.
RAL 9006.



RAL 9010.
RAL 9010.
RAL 9010.
RAL 9010.

COLORES OPCIONALES CUERPO / OPTIONAL BODY COLOURS / COULEURS OPTIONNELS POUR CORPS / CORES DE CORPO OPCIONAIS



RAL 9010 RAL 9001 RAL 1017 RAL 1021 RAL 2004 RAL 4010 RAL 3017 RAL 3000 RAL 3005 RAL 4005 RAL 6029 RAL 6034 RAL 5015 RAL 5023 RAL 5010 RAL 8025 RAL 7035 RAL 9006 RAL 7036 RAL 7016 RAL 9005

ARMARIO METÁLICO DE PERSIANA PVC

METAL CABINET WITH PVC ROLLING DOOR / ARMOAIRE MÉTALLIQUE A RIDEAU PVC / ARMÁRIOS DE ESCRITORIO E PVC

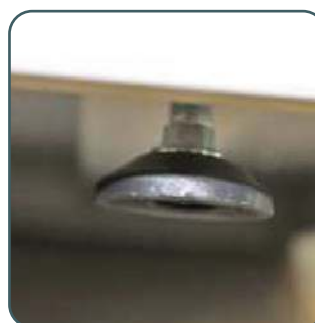
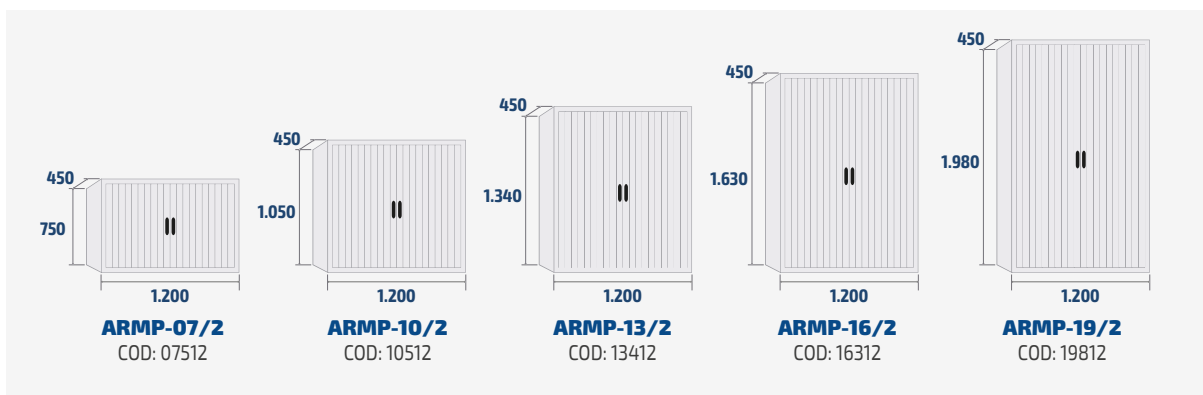
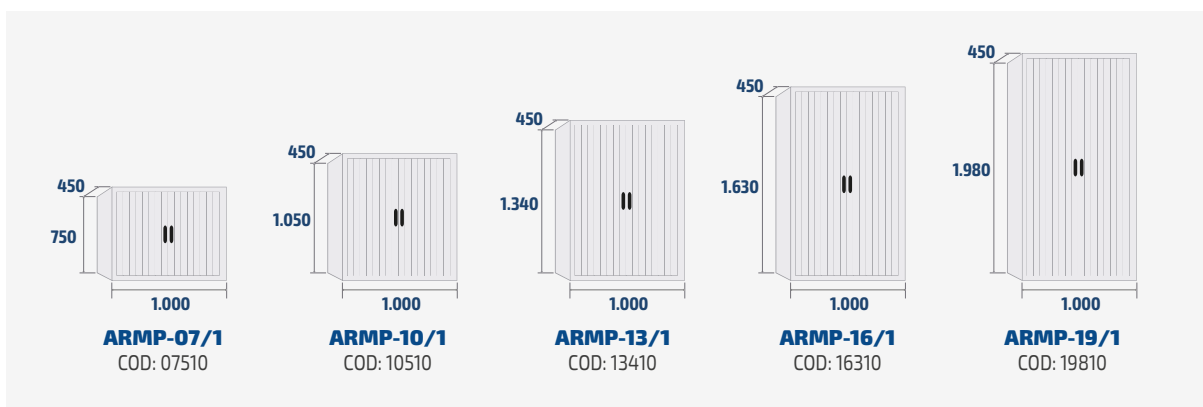

3

TAQUILLAS NO METÁLICAS
NON-METALLIC LOCKERS
VESTIAIRES NON MÉTALLIQUES
ARMÁRIOS NÃO METÁLICOS



TAQUILLAS NO METÁLICAS

NON-METALLIC LOCKERS / VESTIAIRES NON MÉTALLIQUES / CACIFOS NÃO METÁLICOS

TAQUILLAS MELAMINA HIDRÓFUGA
 HYDROPHOBIC MELAMINE LOCKERS /
 VESTIAIRES MÉLAMINE HYDROFUGE /
 CACIFOS MELAMINA HIDRÓFUGA

TAQUILLAS FENÓLICAS CON PERFILERÍA
 HPL LOCKERS WITH ALUMINIUM PROFILE /
 VESTIAIRES EN STRATIFIÉ AVEC PROFILS /
 CACIFOS DE RESINAS FENÓLICAS COM PERFILARIA DE ALUMÍNIO

TAQUILLAS FENÓLICAS
 HPL LOCKERS /
 CASIERS EN STRATIFIÉ /
 CACIFOS DE RESINAS FENÓLICAS

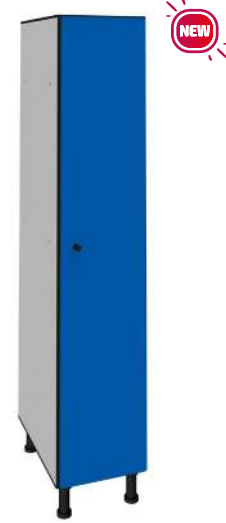

Ambiente
 Environment/Environnement/Ambiente



Húmedo
 Wet
 Humide
 Úmido



Extremadamente húmedo
 Extremely wet
 Extrêmement humide
 Extremadamente úmido



Extremadamente húmedo
 Extremely wet
 Extrêmement humide
 Extremadamente úmido

Acabado / Finish/Finition/Acabamento

Laterales
 Side panel/Latéral/Lateral

Melamina
 Melamine
 Mélamine
 Melamina



Fenólico
 HPL
 Stratifié
 Resinas fenólicas



Fenólico
 HPL
 Stratifié
 Resinas fenólicas



**Puertas / Doors /
 Portes / Portas**

A elegir
 To choose
 Pour choisir
 Para escolher

Melamina / Melamine /
 Mélamine / Melamina



Melamina hidrófuga / Hydrophobic melamine /
 Mélamine hydrofuge / Melamina hidrófuga



Fenólico / HPL /
 Stratifié / Resinas fenólicas



Fenólico
 HPL
 Stratifié
 Resinas fenólicas



Fenólico
 HPL
 Stratifié
 Resinas fenólicas



**Acabado puertas / Door finishing /
 Finition des portes / Acabamento de portas**



Canteado en PVC
 PVC-Edged
 Finitions en PVC
 Finição em PVC



Cantos redondeados
 Rounded edges
 Bords arrondis
 Arestas arredondadas



Cantos redondeados
 Rounded edges
 Bords arrondis
 Arestas arredondadas

Trasera
 Back panel/Partie arrière /Reforço



Tablex perforado
 Perforated tablex
 Tablex perforé
 Tablex perfurado



Fenólico ranurado
 Grooved HPL
 Phénolique rainuré
 Resinas fenólicas ranurado



Fenólico ranurado
 Grooved HPL
 Phénolique rainuré
 Resinas fenólicas ranurado



Opcional / Optional / En option / Opcional

Divisoria Serie V-40

Divider/Séparation industrie salissante/Divisor



Dureza
 Rigidity/Rigidité/Rigidez





TAQUILLAS EN MELAMINA HIDRÓFUGA

LOCKERS IN HYDROPHOBIC MELAMINE / VESTIAIRES EN MÉLAMINE HYDROFUGE / CACIFOS DE MELAMINA HIDRÓFUGA

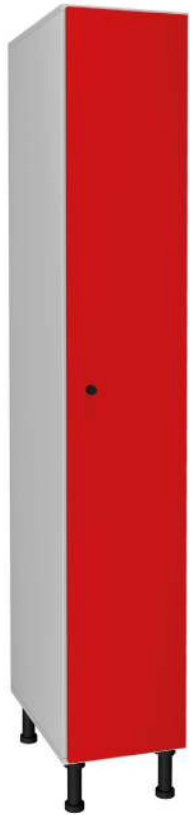

SERIE MHV

1 Puerta
Door
Porte
Porta

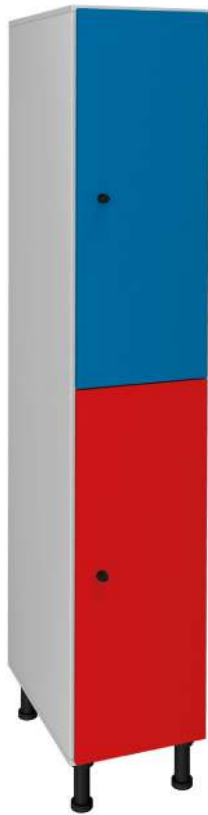

SERIE MHT

2 Puertas
Doors
Portes
Portas

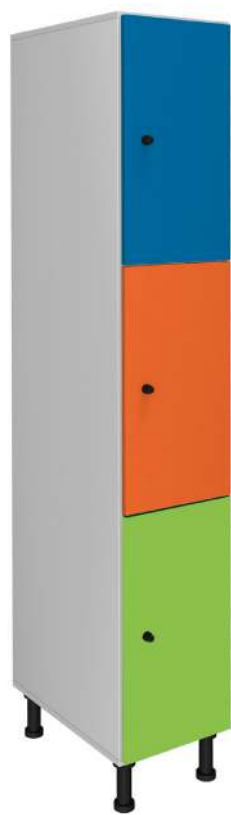

SERIE MHM

3 Puertas
Doors
Portes
Portas

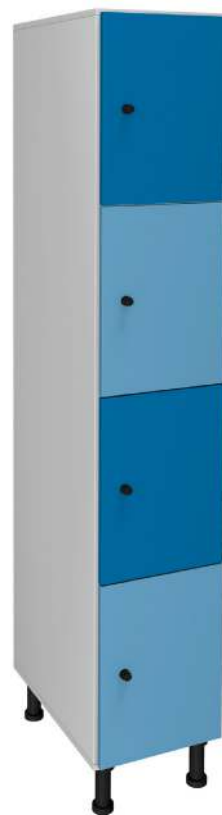

SERIE MHC

4 Puertas
Doors
Portes
Portas



SERIE MHP

5 Puertas
Doors
Portes
Portas



SERIE MHB

6 Puertas
Doors
Portes
Portas



SERIE MHZ

8 Puertas
Doors
Portes
Portas



SERIE MHL*

2 Puertas en forma de L
L-shaped doors
Portes en forme de L
Portas em L



* La serie ML sólo es compatible con puertas fenólicas.
* ML series is only compatible with HPL doors.
* La série ML est uniquement compatible avec les portes phénoliques.
* A série ML é compatível apenas com portas fenólicas.

TAQUILLAS EN MELAMINA HIDRÓFUGA / LOCKERS IN HYDROPHOBIC MELAMINE / VESTIAIRES EN MÉLAMINE HYDROFUGE / CACIFOS DE MELAMINA HIDRÓFUGA



CARACTERÍSTICAS / CHARACTERISTICS / CARACTERISTIQUES / CARACTERISTICAS



Estándar: Cuerpo blanco y puerta a elegir.
Standard: White body and door to choose.
Standard: Corps blanc et portes selon choix.
Padrão: Corpo branco e porta para escolher.



Sin montaje.
Without assembly.
Sans montage.
Sem montagem.



Pata regulable en altura.
Adjustable end cap in height.
Pieds réglables en hauteur.
Pés reguláveis em altura.



Gran resistencia.
High resistance.
Très résistant.
Muito resistente.



Bisagra con freno.
Hinge with brake.
Charnière avec frein.
Dobradiça com freio.



Placa de numeración incluida.
Numeration plate included.
Plaque de numérotation inclus.
Placa de numeração inclusa.



Cerradura de resbalón con bombillo extraíble y llave maestra.
Latch operated lock with removable cylinder and master key.
Serrure à fermeture par glissement avec cylindre extractible et clé passe.
Fechadura de segurança com possibilidade de tirar o cilindro e chave mestre.



Cuerpo canteado PVC.
Body PVC-Edged.
Corps avec chants en PVC.
Corpo finição em PVC.

OPCIONES / OPTIONS / OPTIONS / OPÇÕES



Retenedor de puerta a 90°.
Door opening limiter to 90°.
Dispositif de retenue de la porte a 90°.
Retentor para porta a 90 graus.



Zócalo melamina.
Melamine socle.
Socle en mélamine.
Base de melamina.



Zócalo fenólico.
HPL socle.
Socle en stratifié.
Base de fenólico.



Sobretecho inclinado.
Slope Top.
Toit incliné.
Sobreteto com inclinação.



Lateral embellecedor.
Decorative end panel.
Enjoliveur latéral.
Lateral de finição.



Pulsera de nylon.
Nylon bracelet.
Bracelet en nylon.
Pulseira de náilon.



Pulsera elástica.
Elastic Bracelet.
Bracelet élastique.
Pulseira elástica.



Cierre para candado.
Closing for padlock.
Fermeture pour cadenas.
Fechadura para cadeado.

PUERTA MELAMINA HIDRÓFUGA / HYDROPHOBIC MELAMINE DOOR / PORTE MÉLAMINE HYDROFUGE / PORTA MELAMINA HIDRÓFUGA



Blanco M-060 Gris claro M-34W Rojo M-172 Azul oscuro M-155C Gris oscuro M-4AT

PUERTA MELAMINA / MELAMINE DOOR / PORTE MÉLAMINE / PORTA MELAMINA



Crema M-183 Amarillo M-22G Naranja M-28G Rosa M-35W Verde M-023 Azul claro M-US22 Aluminio M-72E Negro M-231 Haya MM-240 Wengue M-52A



Acacia M-50D Roble Caledorian M-51S Roble joplin M-17N Roble azabache M-75V Fresno taiga M-18N Cemento apolo M-99Q Cemento teide M-06F

SISTEMAS DE APERTURA / OPENING SYSTEM / SYSTÈMES D'OUVERTURE / SISTEMA DE ABERTURA

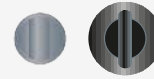

Pomo en poliamida / metálico.
Padlockable polyamide Lock / metallic Lock.
Serrure à porte cadenas en polyamide/métallique
Fechadura de cadeado em poliamida / metal.



Tirador metálico.
Metal handle.
Poignée en métal.
Cabo de metal.



Cerraduras de proximidad.
RFID Locks.
Serrures de proximité.
Fechaduras de proximidade.



Cerradura de combinación y llave de emergencia.
Manual combination lock with emergency key.
Serrure à combinaison de 4 chiffres et clé de secours.
Fechadura de combinação e chave de emergência.



Monedero con moneda retornable/con cajetín depósito.
Coin-operated Lock with coin-return/collect box.
Monnaie avec monnaie retournable/tirelire.
Moedeiro moeda retornável/caixinha.



Cerraduras electrónicas de combinación de 4 dígitos.
Electronic combination locks of 4 digits.
Serrures électroniques à combinaison de 4 chiffres.
Fechaduras electrónicas, combinação de 4 dígitos.

PUERTA FENÓLICA / PHENOLIC DOOR / PORTE PHÉNOLIQUE / PORTA FENÓLICA



Blanco F-085 Gris claro F-0074 Crema F-0851 Amarillo F-0010 Naranja F-0011 Rosa F-0232 Rojo F-0210 Verde claro F-0725 Verde oscuro F-6901 Turquesa F-2478



Burdeos F-0318 Azul claro F-0718 Azul oscuro F-0717 Aluminio F-0193 Gris oscuro F-0077 Negro F-0080 Madera Clara FM-100 Madera oscura FM-200 Wengue FF-405



Fácil limpieza.
Easy cleaning.
Nettoyage facile.
Fácil limpeza.



TAQUILLAS EN MELAMINA HIDRÓFUGA

LOCKERS IN HYDROPHOBIC MELAMINE / VESTIAIRES EN MÉLAMINE HYDROFUGE / CACIFOS DE MELAMINA HIDRÓFUGA

Detalles constructivos/Construction details/
Détails de la construction/Detalhes de construção



Patas regulables en PVC/Adjustable PVC Legs/
Pieds réglables en PVC/Pés reguláveis em altura em PVC



Bisagra con freno/Hinge with brake/
Charnière avec frein/Dobradiça com freio



Interior SERIE MHV Divisoria opcional en la serie MHV-40/
Optional divider at MHV-40 serie /
Séparation industrie salissante en option sur la série MHV-40/
Divisor opcional na série MHV-40

Opciones /Options/
Options /Opções



Sobretecho inclinado/Slope Top
Toit incliné/Sobreteto com inclinação



Zócalo fenólico/HPL socle
Socle en stratifié/Base de fenólico

Cerraduras/Locks/Serrures/Fechaduras



Pomo en poliamida y placa de numeración/
Padlockable polyamide lock and numeration plate/
Serrure à porte cadenas en polyamide et plaque de numérotation/
Fechadura de cadeado em poliamida e placa de numeração

TAQUILLAS EN MELAMINA HIDRÓFUGA

LOCKERS IN HYDROPHOBIC MELAMINE / VESTIAIRES EN MÉLAMINE HYDROFUGE / CACIFOS DE MELAMINA HIDRÓFUGA

MHP-30/4





TAQUILLAS EN MELAMINA HIDRÓFUGA

LOCKERS IN HYDROPHOBIC MELAMINE / VESTIAIRES EN MÉLAMINE HYDROFUGE / CACIFOS DE MELAMINA HIDRÓFUGA

SERIE MHV

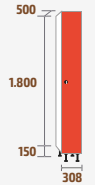

MHV-30/1
COD: 99276 | 58501
32kg | 34kg · 0,28m³

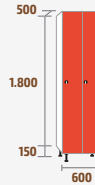

MHV-30/2
COD: 99278 | 58502
54kg | 59kg · 0,54m³

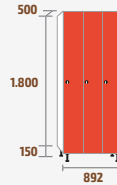

MHV-30/3
COD: 99279 | 58509
77kg | 83kg · 0,80m³

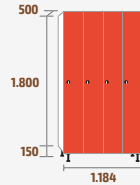

MHV-30/4
COD: 99280 | 58601
99kg | 108kg · 1,07m³

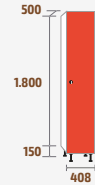

MHV-40/1
COD: 99283 | 58505
36kg | 37kg · 0,37m³

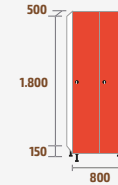

MHV-40/2
COD: 99284 | 58506
62kg | 68kg · 0,72m³

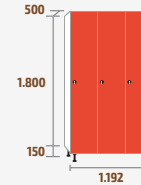

MHV-40/3
COD: 99285 | 58602
89kg | 97kg · 1,07m³

SERIE MHT

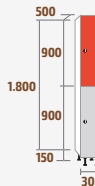

MHT-30/1
COD: 99277 | 58511
33kg | 35kg · 0,28m³

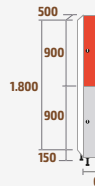

MHT-30/2
COD: 99578 | 58512
55kg | 60kg · 0,54m³

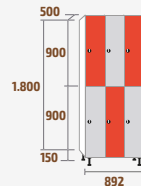

MHT-30/3
COD: 99579 | 58519
78kg | 85kg · 0,80m³

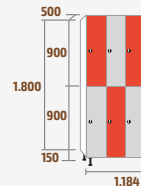

MHT-30/4
COD: 99580 | 58605
101kg | 110kg · 1,07m³

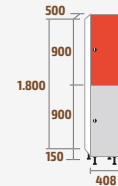

MHT-40/1
COD: 99352 | 58515
36kg | 39kg · 0,37m³



MHT-40/2
COD: 99402 | 58516
63kg | 69kg · 0,72m³



MHT-40/3
COD: 99403 | 58606
90kg | 99kg · 1,07m³

SERIE MHM

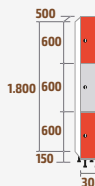

MHM-30/1
COD: 99350 | 58531
35kg | 37kg · 0,28m³

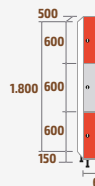

MHM-30/2
COD: 99412 | 58532
60kg | 64kg · 0,54m³

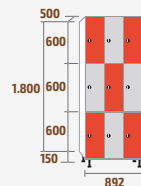

MHM-30/3
COD: 99413 | 58539
84kg | 91kg · 0,80m³

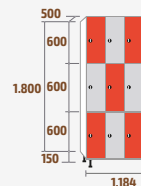

MHM-30/4
COD: 99414 | 58609
110kg | 118kg · 1,07m³

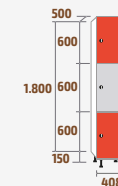

MHM-40/1
COD: 99353 | 58535
39kg | 42kg · 0,37m³

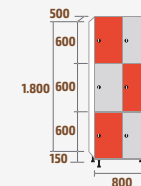

MHM-40/2
COD: 99415 | 58536
68kg | 74kg · 0,72m³

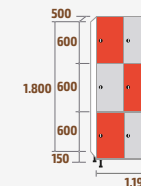

MHM-40/3
COD: 99416 | 58610
98kg | 107kg · 1,07m³

SERIE MHC

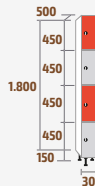

MHC-30/1
COD: 99351 | 58521
37kg | 39kg · 0,28m³

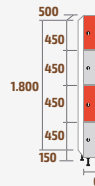

MHC-30/2
COD: 99422 | 58522
64kg | 68kg · 0,54m³

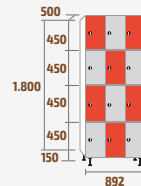

MHC-30/3
COD: 99423 | 58529
91kg | 97kg · 0,80m³

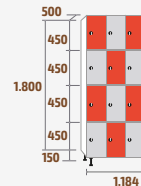

MHC-30/4
COD: 99424 | 58613
118kg | 127kg · 1,07m³

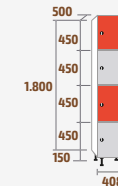

MHC-40/1
COD: 99354 | 58525
42kg | 45kg · 0,37m³

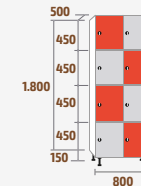

MHC-40/2
COD: 99425 | 58526
74kg | 79kg · 0,72m³

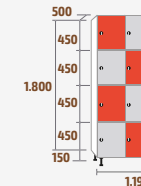

MHC-40/3
COD: 99426 | 58614
106kg | 115kg · 1,07m³

TAQUILLAS EN MELAMINA HIDRÓFUGA

LOCKERS IN HYDROPHOBIC MELAMINE / VESTIAIRES EN MÉLAMINE HYDROFUGE / CACIFOS DE MELAMINA HIDRÓFUGA



SERIE MHP

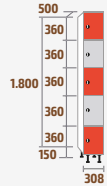

MHP-30/1
COD: 99551 | 58551
39kg | 41kg · 0,28m³

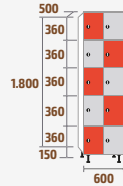

MHP-30/2
COD: 99552 | 58552
68kg | 72kg · 0,54m³

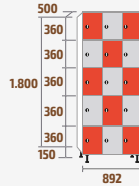

MHP-30/3
COD: 99553 | 58559
97kg | 104kg · 0,80m³

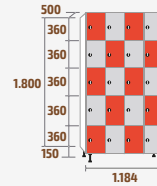

MHP-30/4
COD: 99555 | 58617
126kg | 135kg · 1,07m³

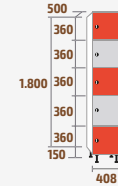

MHP-40/1
COD: 99554 | 58565
44kg | 47kg · 0,37m³

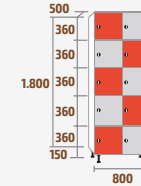

MHP-40/2
COD: 99559 | 58566
79kg | 85kg · 0,72m³

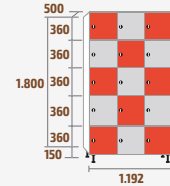

MHP-40/3
COD: 99560 | 58618
114kg | 123kg · 1,07m³

SERIE MHB

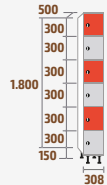

MHB-30/1
COD: 99651 | 58561
41kg | 43kg · 0,28m³

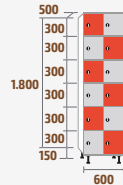

MHB-30/2
COD: 99652 | 58562
72kg | 77kg · 0,54m³

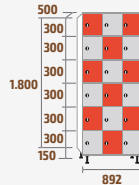

MHB-30/3
COD: 99653 | 58569
103kg | 110kg · 0,80m³



MHB-30/4
COD: 99655 | 58621
135kg | 144kg · 1,07m³

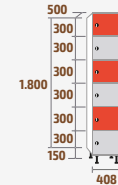

MHB-40/1
COD: 99654 | 58575
47kg | 50kg · 0,37m³

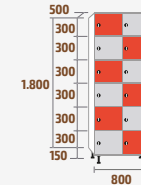

MHB-40/2
COD: 99659 | 58576
84kg | 90kg · 0,72m³

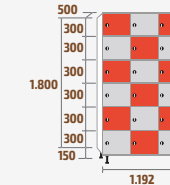

MHB-40/3
COD: 99660 | 58622
122kg | 130kg · 1,07m³

SERIE MHZ

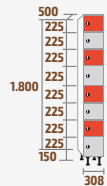

MHZ-30/1
COD: 99851 | 58581
45kg | 47kg · 0,28m³

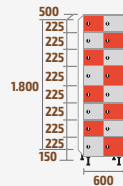

MHZ-30/2
COD: 99852 | 58582
81kg | 85kg · 0,54m³

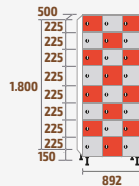

MHZ-30/3
COD: 99853 | 58589
116kg | 123kg · 0,80m³

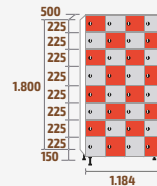

MHZ-30/4
COD: 99855 | 58625
152kg | 160kg · 1,07m³

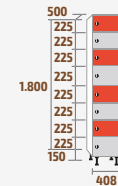

MHZ-40/1
COD: 99854 | 58585
52kg | 55kg · 0,37m³

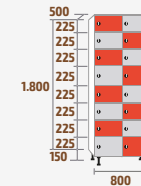

MHZ-40/2
COD: 99859 | 58586
94kg | 100kg · 0,72m³

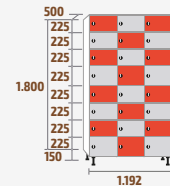

MHZ-40/3
COD: 99860 | 58626
138kg | 146kg · 1,07m³

SERIE MHL



MHL-30/1
COD: 58541
40kg · 0,28m³

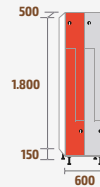

MHL-30/2
COD: 58542
69kg · 0,54m³

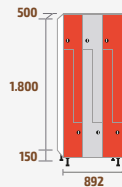

MHL-30/3
COD: 58549
99kg · 0,80m³

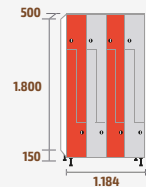

MHL-30/4
COD: 58629
129kg · 1,07m³

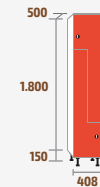

MHL-40/1
COD: 58545
44kg · 0,37m³

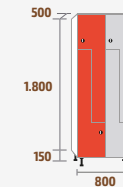

MHL-40/2
COD: 58546
79kg · 0,72m³

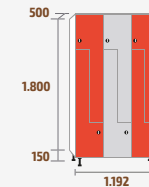

MHL-40/3
COD: 58630
113kg · 1,07m³

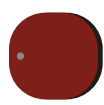

TAQUILLAS FENÓLICAS

HPL LOCKERS / VESTIAIRES EN STRATIFIÉ / CACIFOS DE RESINAS FENÓLICAS

TAQUILLAS FENÓLICAS CON PERFILERÍA / HPL LOCKERS WITH ALUMINIUM PROFILE / VESTIAIRES EN STRATIFIE AVEC PROFILS / CACIFOS DE RESINAS FENÓLICAS COM PERFILARIA DE ALUMÍNIO



SERIE FVP

1 Puerta
Door
Porte
Porta



SERIE FTP

2 Puertas
Doors
Portes
Portas



SERIE FMP

3 Puertas
Doors
Portes
Portas



SERIE FCP

4 Puertas
Doors
Portes
Portas



SERIE FPP

5 Puertas
Doors
Portes
Portas



SERIE FBP

6 Puertas
Doors
Portes
Portas



SERIE FZP

8 Puertas
Doors
Portes
Portas



SERIE FLP

2 Puertas en forma de L
L-shaped doors
Portes en forme de L
Portas em L

TAQUILLAS FENÓLICAS / HPL LOCKERS / CASIERS EN STRATIFIÉ / CACIFOS DE RESINAS FENÓLICAS

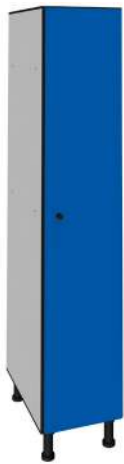

SERIE FV

1 Puerta
Door
Porte
Porta

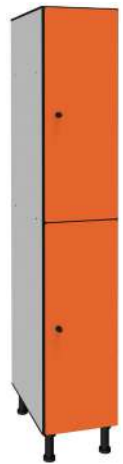

SERIE FT

2 Puertas
Doors
Portes
Portas



SERIE FM

3 Puertas
Doors
Portes
Portas

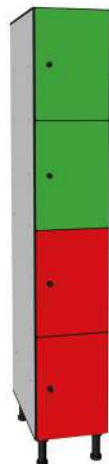

SERIE FC

4 Puertas
Doors
Portes
Portas



SERIE FP

5 Puertas
Doors
Portes
Portas

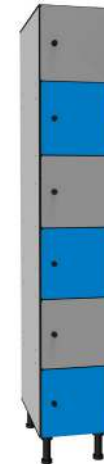

SERIE FB

6 Puertas
Doors
Portes
Portas

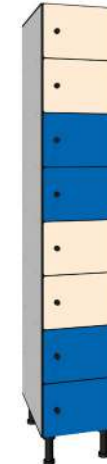

SERIE FZ

8 Puertas
Doors
Portes
Portas



SERIE FL

2 Puertas en forma de L
L-shaped doors
Portes en forme de L
Portas em L



SERIE FLH

2 Puertas en forma de L
L-shaped doors
Portes en forme de L
Portas em L

CARACTERÍSTICAS / CHARACTERISTICS / CARACTERISTIQUES / CARACTERISTICAS



Estándar: Cuerpo blanco y puerta a elegir.
Standard: White body and door to choose.
Standard: Corps blanc et portes selon choix.
Padrão: Corpo branco e porta para escolher.



Sin montaje.
Without assembly.
Sans montage.
Sem montagem.



Pata regulable en altura.
Adjustable end cap in height.
Pieds réglables en hauteur.
Pés reguláveis em altura.



Material de gran resistencia, hidrófugo, ignífugo y antibacteriano.
Material of great resistance, hydrophobic, fire resistant and antibacterial.
Matériel très résistant, hydrofuge, ignifuge et antibactérien.
Material muito resistente, hidrófugo, ignífugo e antibacteriano.



Placa de numeración incluida.
Numeration plate included.
Plaque de numérotation inclus.
Placa de numeração inclusa.



Fácil limpieza.
Easy cleaning.
Nettoyage facile.
Fácil limpeza.



Tornillería y bisagras en acero inoxidable.
Screws and hinges in stainless steel.
Visserie et charnières en acier inoxydable.
Parafusos e dobradiças em aço inox.



Cerradura de resbalón con bombillo extraíble y llave maestra.
Latch operated lock with removable cylinder and master key.
Serrure à fermeture par glissement avec cylindre extractible et clé passe.
Fechadura de segurança com possibilidade de tirar o cilindro e chave mestre.

TAQUILLAS FENÓLICAS CON PERFILERÍA /
HPL LOCKERS WITH ALUMINIUM PROFILE /
VESTIAIRES EN STRATIFIÉ AVEC PROFILS /
CACIFOS DE RESINAS FENÓLICAS COM PERFILARIA DE ALUMÍNIO



Perfilería de aluminio.
Aluminum profiles.
Profils en aluminium.
Perfis de alumínio.

SISTEMAS DE APERTURA / OPENING SYSTEM / SYSTÈMES D'OUVERTURE / SISTEMA DE ABERTURA

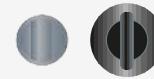

Pomo en poliamida / metálico.
Padlockable polyamide Lock / metallic Lock.
Serrure à porte cadenas en polyamide/métallique.
Fechadura de cadeado em poliamida / metal.



Cerradura de combinación y llave de emergencia.
Manual combination lock with emergency key.
Serrure à combinaison de 4 chiffres et clé de secours.
Fechadura de combinação e chave de emergência.



Tirador metálico.
Metal handle.
Poignée en métal.
Cabo de metal.



Monedero con moneda retornable/con cajetín depósito.
Coin-operated Lock with coin-return/collect box.
Monnayeur avec monnaie retournable/tirelire.
Moedeiro moeda retornável/caixinha.



Cerraduras de proximidad.
RFID Locks.
Serrures de proximité.
Fechaduras de proximidade.



Cerraduras electrónicas de combinación de 4 dígitos.
Electronic combination locks of 4 digits.
Serrures électroniques à combinaison de 4 chiffres.
Fechaduras electrónicas, combinação de 4 dígitos.

OPCIONES / OPTIONS / OPTIONS / OPÇÕES



Retenedor de puerta a 90°.
Door opening limiter 90°.
Dispositif de retenue de la porte a 90°.
Retentor para porta a 90 graus.



Zócalo fenólico.
HPL socle.
Socle en stratifié.
Base de fenólico.



Sobretecho inclinado.
Slope Top.
Toit incliné.
Sobreteto com inclinação.



Lateral embellecedor.
Decorative end panel.
Enjoliveur latéral.
Lateral de feição.



Pulsera de nylon.
Nylon bracelet.
Bracelet en nylon.
Pulseira de náilon.



Pulsera elástica.
Elastic Bracelet.
Bracelet élastique.
Pulseira elástica.



Cierre para candado.
Closing for padlock.
Fermeture pour cadenas.
Fechadura para cadeado.

COLORES OPCIONALES PUERTAS / OPTIONAL DOOR COLOURS / COULEURS OPTIONNELS POUR LES PORTES / CORES DE PORTAS OPCIONAIS

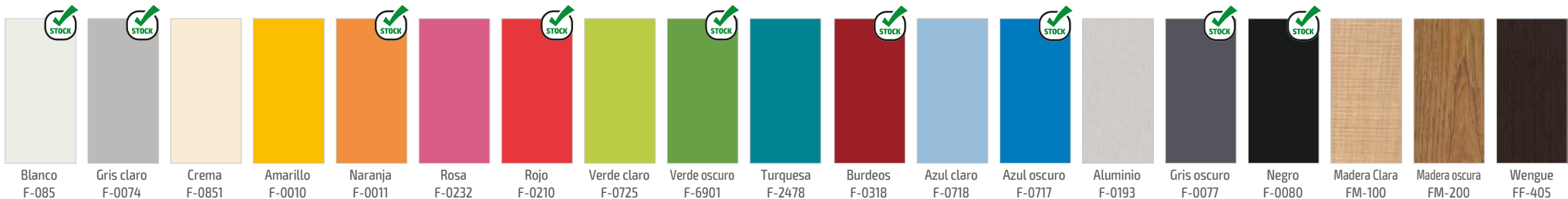



TAQUILLAS FENÓLICAS

HPL LOCKERS / VESTIAIRES EN STRATIFIÉ / CACIFOS DE RESINAS FENÓLICAS

Detalles constructivos/Construction details/
Détails de la construction/Detalhes de construção



Perfilería de aluminio/Aluminum profiles/
Profils en aluminium/Perfis de alumínio

Trasera/Back panel/Partie arrière /Reforço



Fenólico ranurado/Grooved HPL/
Phénolique rainuré/Resinas fenólicas ranhurado

Cerraduras/Locks/Serrures/Fechaduras



Cerradura de resbalón/ Latch operated lock /
Serrure à fermeture par glissement /Fechadura de segurança.



Interior **SERIE FPV**

Opciones /Options/Options /Opções



Perfilería de aluminio / Aluminum profiles /
Profils en aluminium / Perfis de alumínio.



TAQUILLAS FENÓLICAS
HPL LOCKERS /
CASIERS EN STRATIFIÉ /
CACIFOS DE RESINAS FENÓLICAS



TAQUILLAS FENÓLICAS CON PERFILERÍA
HPL LOCKERS WITH ALUMINIUM PROFILE /
VESTIAIRES EN STRATIFIÉ AVEC PROFILS /
CACIFOS DE RESINAS FENÓLICAS COM PERFILARIA DE ALUMÍNIO

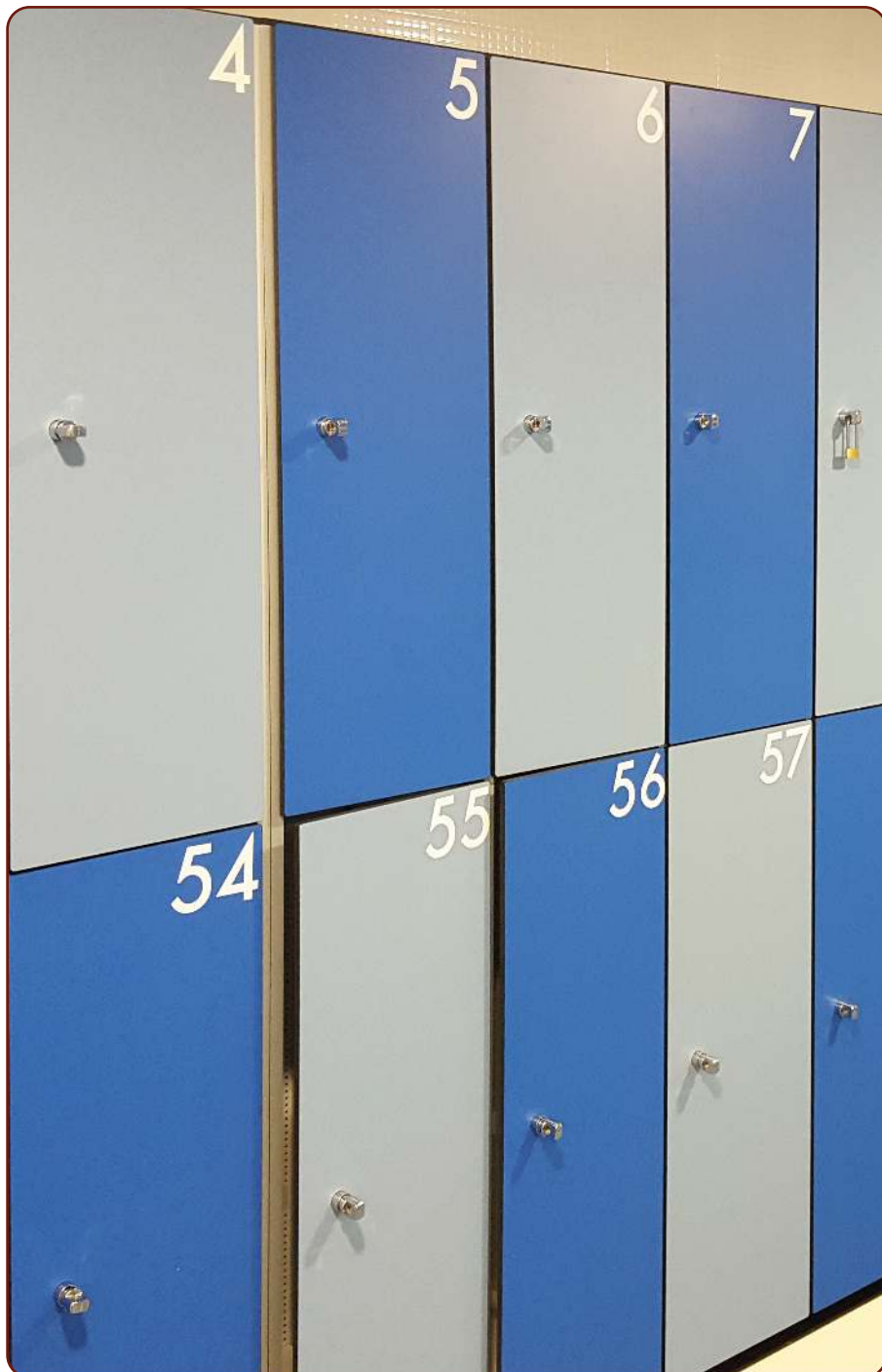



TAQUILLAS FENÓLICAS

HPL LOCKERS / VESTIAIRES EN STRATIFIÉ / CACIFOS DE RESINAS FENÓLICAS

SERIE FVP
SERIE FV

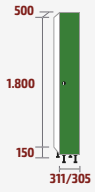

FVP-30/1
COD: 53501 · 31kg · 0,28m³
FV-30/1
COD: 53001 · 43,6kg · 0,27m³



FVP-30/2
COD: 53502 · 55kg · 0,54m³
FV-30/2
COD: 53101 · 74,05kg · 0,54m³

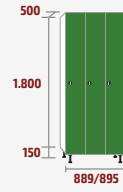

FVP-30/3
COD: 53509 · 79kg · 0,80m³
FV-30/3
COD: 53102 · 104,3kg · 0,81m³

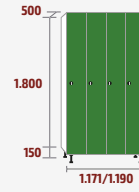

FVP-30/4
COD: 53601 · 104kg · 1,07m³
FV-30/4
COD: 53103 · 134,85kg · 1,07m³

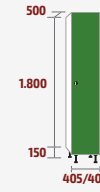

FVP-40/1
COD: 53505 · 37kg · 0,37m³
FV-40/1
COD: 53002 · 49kg · 0,36m³

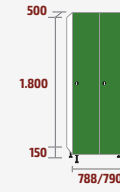

FVP-40/2
COD: 53506 · 66kg · 0,72m³
FV-40/2
COD: 53112 · 84,85kg · 0,71m³

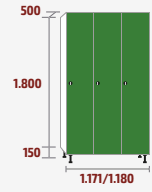

FVP-40/3
COD: 53602 · 96kg · 1,07m³
FV-40/3
COD: 53113 · 120,8kg · 1,06m³

SERIE FTP
SERIE FT

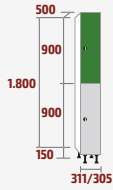

FTP-30/1
COD: 53511 · 32kg · 0,28m³
FT-30/1
COD: 53011 · 44,1kg · 0,27m³

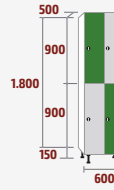

FTP-30/2
COD: 53512 · 56kg · 0,54m³
FT-30/2
COD: 53120 · 75,05kg · 0,54m³

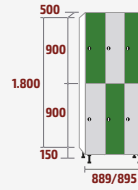

FTP-30/3
COD: 53519 · 81kg · 0,80m³
FT-30/3
COD: 53121 · 105,8kg · 0,81m³

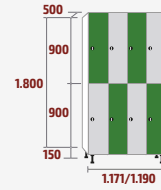

FTP-30/4
COD: 53605 · 106kg · 1,07m³
FT-30/4
COD: 53122 · 136,85kg · 1,07m³

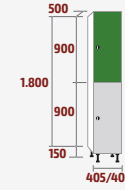

FTP-40/1
COD: 53515 · 37kg · 0,37m³
FT-40/1
COD: 53012 · 49,5kg · 0,36m³

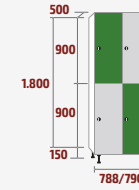

FTP-40/2
COD: 53516 · 67kg · 0,72m³
FT-40/2
COD: 53123 · 85,85kg · 0,71m³

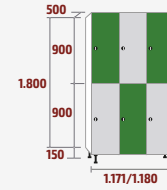

FTP-40/3
COD: 53606 · 97kg · 1,07m³
FT-40/3
COD: 53124 · 122,3kg · 1,06m³

SERIE FMP
SERIE FM

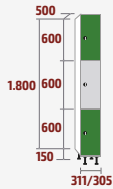

FMP-30/1
COD: 53531 · 34kg · 0,28m³
FM-30/1
COD: 53031 · 47kg · 0,27m³

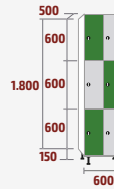

FMP-30/2
COD: 53532 · 62kg · 0,54m³
FM-30/2
COD: 53131 · 80kg · 0,54m³

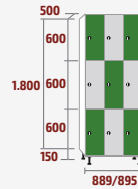

FMP-30/3
COD: 53539 · 89kg · 0,80m³
FM-30/3
COD: 53132 · 114kg · 0,81m³

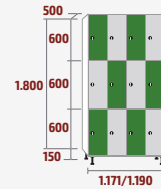

FMP-30/4
COD: 53609 · 116kg · 1,07m³
FM-30/4
COD: 53133 · 148kg · 1,07m³

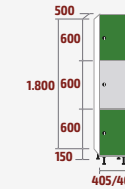

FMP-40/1
COD: 53535 · 40kg · 0,37m³
FM-40/1
COD: 53032 · 53kg · 0,36m³



FMP-40/2
COD: 53536 · 74kg · 0,72m³
FM-40/2
COD: 53134 · 93kg · 0,71m³

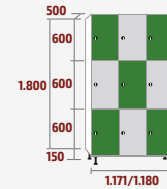

FMP-40/3
COD: 53610 · 108kg · 1,07m³
FM-40/3
COD: 53135 · 133kg · 1,06m³

SERIE FCP
SERIE FC

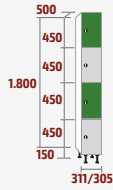

FCP-30/1
COD: 53521 · 37kg · 0,28m³
FC-30/1
COD: 53021 · 50kg · 0,27m³

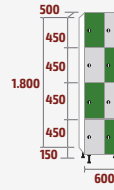

FCP-30/2
COD: 53522 · 67kg · 0,54m³
FC-30/2
COD: 53141 · 86kg · 0,54m³

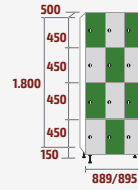

FCP-30/3
COD: 53529 · 97kg · 0,80m³
FC-30/3
COD: 53142 · 122kg · 0,81m³

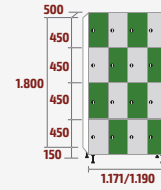

FCP-30/4
COD: 53613 · 127kg · 1,07m³
FC-30/4
COD: 53143 · 158kg · 1,07m³

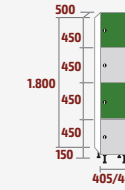

FCP-40/1
COD: 53525 · 44kg · 0,37m³
FC-40/1
COD: 53022 · 56kg · 0,36m³

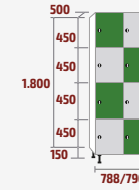

FCP-40/2
COD: 53526 · 81kg · 0,72m³
FC-40/2
COD: 53144 · 99kg · 0,71m³

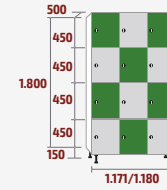

FCP-40/3
COD: 53614 · 118kg · 1,07m³
FC-40/3
COD: 53145 · 143kg · 1,06m³

TAQUILLAS FENÓLICAS

HPL LOCKERS / VESTIARES EN STRATIFIÉ / CACIFOS DE RESINAS FENÓLICAS



SERIE FPP SERIE FP

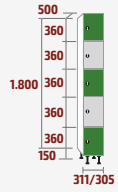

FPP-30/1
COD: 53551 · 40kg · 0,28m³
FP-30/1
COD: 53051 · 52kg · 0,27m³

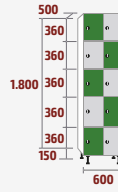

FPP-30/2
COD: 53552 · 73kg · 0,54m³
FP-30/2
COD: 53151 · 91kg · 0,54m³

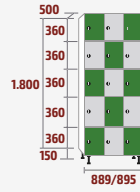

FPP-30/3
COD: 53559 · 105kg · 0,80m³
FP-30/3
COD: 53152 · 130kg · 0,81m³

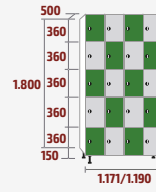

FPP-30/4
COD: 53617 · 138kg · 1,07m³
FP-30/4
COD: 53153 · 169kg · 1,07m³

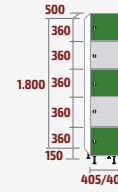

FPP-40/1
COD: 53565 · 47kg · 0,37m³
FP-40/1
COD: 53052 · 60kg · 0,36m³

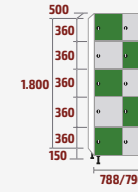

FPP-40/2
COD: 53566 · 88kg · 0,72m³
FP-40/2
COD: 53154 · 106kg · 0,71m³

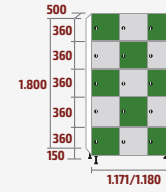

FPP-40/3
COD: 53618 · 128kg · 1,07m³
FP-40/3
COD: 53155 · 153kg · 1,06m³

SERIE FBP SERIE FB

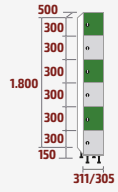

FBP-30/1
COD: 53561 · 42kg · 0,28m³
FB-30/1
COD: 53061 · 55kg · 0,27m³

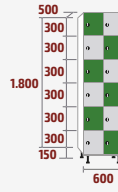

FBP-30/2
COD: 53562 · 78kg · 0,54m³
FB-30/2
COD: 53161 · 96kg · 0,54m³

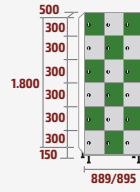

FBP-30/3
COD: 53569 · 113kg · 0,80m³
FB-30/3
COD: 53162 · 138kg · 0,81m³

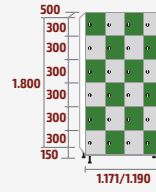

FBP-30/4
COD: 53621 · 149kg · 1,07m³
FB-30/4
COD: 53163 · 180kg · 1,07m³

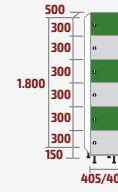

FBP-40/1
COD: 53575 · 51kg · 0,37m³
FB-40/1
COD: 53062 · 63kg · 0,36m³

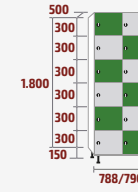

FBP-40/2
COD: 53576 · 94kg · 0,72m³
FB-40/2
COD: 53164 · 113kg · 0,71m³

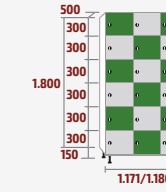

FBP-40/3
COD: 53622 · 139kg · 1,07m³
FB-40/3
COD: 53165 · 164kg · 1,06m³

SERIE FZP SERIE FZ

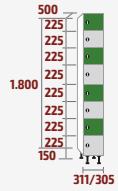

FZP-30/1
COD: 53581 · 48kg · 0,28m³
FZ-30/1
COD: 53081 · 60kg · 0,27m³

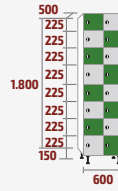

FZP-30/2
COD: 53582 · 89kg · 0,54m³
FZ-30/2
COD: 53171 · 107kg · 0,54m³

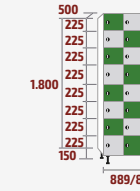

FZP-30/3
COD: 53589 · 129kg · 0,80m³
FZ-30/3
COD: 53172 · 154kg · 0,81m³

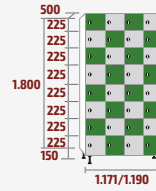

FZP-30/4
COD: 53625 · 170kg · 1,07m³
FZ-30/4
COD: 53173 · 201kg · 1,07m³

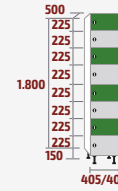

FZP-40/1
COD: 53585 · 57kg · 0,37m³
FZ-40/1
COD: 53082 · 70kg · 0,36m³

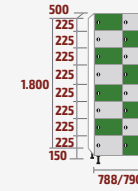

FZP-40/2
COD: 53586 · 108kg · 0,72m³
FZ-40/2
COD: 53174 · 127kg · 0,71m³

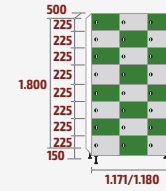

FZP-40/3
COD: 53626 · 159kg · 1,07m³
FZ-40/3
COD: 53175 · 184kg · 1,06m³

SERIE FLP/FL SERIE FLH

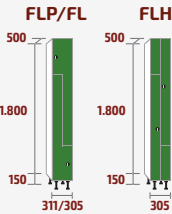

FLP-30/1
COD: 53541 · 38kg · 0,28m³
FL-30/1
COD: 53041 · 51kg · 0,27m³
FLH-30/1
COD: 21000

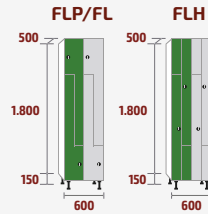

FLP-30/2
COD: 53542 · 70kg · 0,54m³
FL-30/2
COD: 53181 · 92kg · 0,54m³
FLH-30/2
COD: 21001

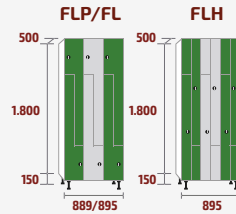

FLP-30/3
COD: 53549 · 101kg · 0,80m³
FL-30/3
COD: 53182 · 134kg · 0,81m³
FLH-30/3
COD: 21002

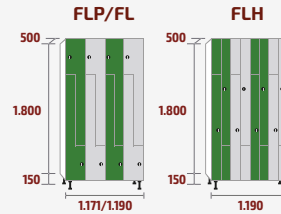

FLP-30/4
COD: 53629 · 132kg · 1,07m³
FL-30/4
COD: 53183 · 175kg · 1,07m³
FLH-30/4
COD: 21003

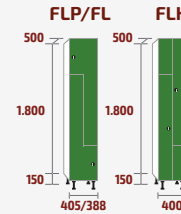

FLP-40/1
COD: 53545 · 44kg · 0,36m³
FL-40/1
COD: 53042 · 56kg · 0,36m³
FLH-40/1
COD: 21004

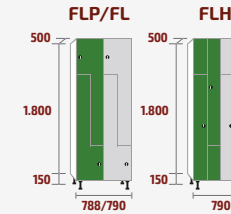

FLP-40/2
COD: 53546 · 80kg · 0,71m³
FL-40/2
COD: 53184 · 103kg · 0,71m³
FLH-40/2
COD: 21005

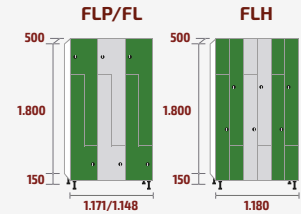

FLP-40/3
COD: 53630 · 117kg · 1,05m³
FL-40/3
COD: 53185 · 150kg · 1,06m³
FLH-40/3
COD: 21006



CABINAS FENÓLICAS

HPL-CUBICLES / CABINES SANITAIRES EN STRATIFIÉ / CABINES DE RESINAS FENÓLICAS

CARACTERÍSTICAS / CHARACTERISTICS / CARACTERISTIQUES / CARACTERISTICAS



Espesores.
Thicknesses.
Épaisseurs.
Espessura.

HPL

Cabinas fabricadas en tablero de compacto fenólico.
Cubicles manufactured with HPL panels, made of phenolic resins.
Cabines fabriqués en stratifié compact.
Cabines construídos em resinas fenólicas.



Cantos redondeados.
Rounded edges.
Bords arrondis.
Cantos redondeados.

INOX

Tornillería y bisagras en acero inoxidable.
Screws and hinges in stainless steel.
Visserie et charnières en acier inoxydable.
Parafusos e dobradiças em aço inox.



Pata regulable en altura.
Adjustable end cap in height.
Pieds réglables en hauteur.
Pés reguláveis em altura.



Material de gran resistencia, hidrófugo, ignífugo y antibacteriano.
Material of great resistance, hydrophobic, fire resistant and antibacterial.
Matériel très résistant, hydrofuge, ignifuge et antibactérien.
Material muito resistente, hidrófugo, ignífugo e antibacteriano.



Fácil limpieza.
Easy cleaning.
Nettoyage facile.
Fácil limpeza.



Recomendado para ambientes húmedos. Resistente al agua.
Recommended for humid environments. Water resistant.
Indiqué pour des endroits avec de l'humidité. Résistant à l'eau.
Recomendado para lugares com humidade. Resistente al água.



OPCIONES / OPTIONS / OPTIONS / OPÇÕES

INOX

Inox.
Stainless steel.
Inox.
Inox.

COLORES STANDARD / STANDARD COLOURS / COULEURS STANDARD / CORES STANDARD

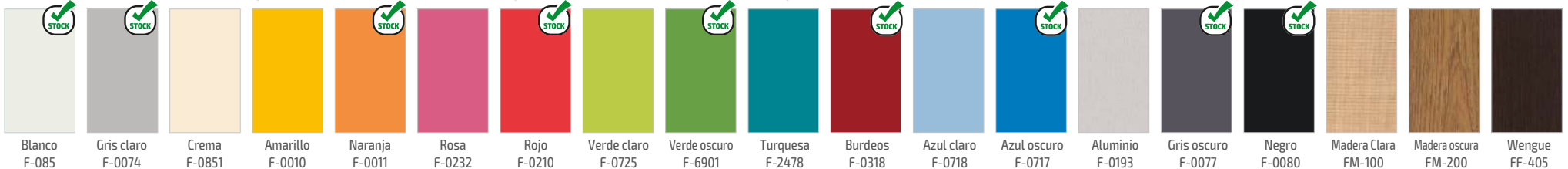

Detalles constructivos/Construction details/
Détails de la construction/Detalhes de construção

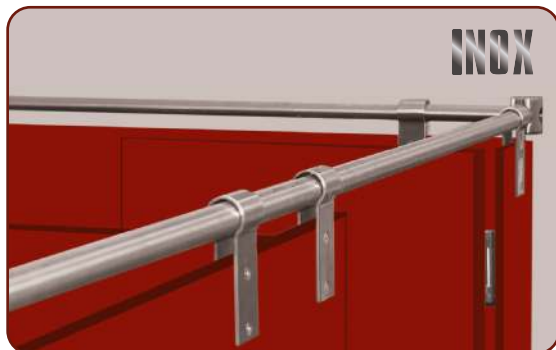

HPL-CUBICLES / CABINES SANITAIRES EN STRATIFIÉ / CABINES DE RESINAS FENÓLICAS

CABINAS FENÓLICAS



BANCOS DE VESTUÁRIO
BENCHES
BANCS POUR VESTIAIRES
BANCOS DE VESTIÁRIO

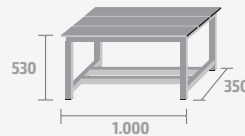

BANC-H-1000
COD: 79100
12kg · 0,19m³

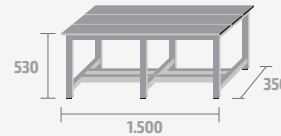

BANC-H-1500
COD: 79150
18kg · 0,28m³

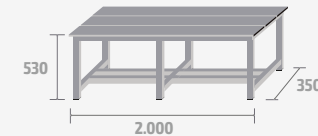

BANC-H-2000
COD: 79200
24kg · 0,37m³

CARACTERÍSTICAS / CHARACTERISTICS / CARACTERISTIQUES / CARACTERISTICAS



RAL 7035

Estándar: Gris RAL 7035.
Standard: Grey RAL 7035.
Standard: Gris RAL 7035.
Padrão: Cinza RAL 7035.



Microtexturado.
Microtextured.
Microtexturé.
Microtexturado.



Gran resistencia.
High resistance.
Très résistant.
Muito resistente.



Chasis en tubo de acero.
Steel tube chassis.
Châssis en tube d'acier.
Construção em tubo de aço soldado.



No es recomendable para espacios húmedos.
Not recommended for wet spaces.
Pas recommandé pour les environnements humides.
Nao é recomendável para lugares com humidade.

OPCIONES / OPTIONS / OPTIONS / OPÇÕES



Fijación a suelo.
Floor fixing.
Fixation au sol.
Fixação piso.



Contera regulable en altura.
Adjustable end cap.
Pieds réglables en hauteur.
Pés reguláveis.

COLORES OPCIONALES CHASIS / OPTIONAL CHASSIS COLOURS / COULEURS POUR CHÂSSIS EN OPTION / CORES CHASSI OPCIONAIS



RAL 9010 RAL 9001 RAL 1017 RAL 1021 RAL 2004 RAL 4010 RAL 3017 RAL 3000 RAL 3005 RAL 4005 RAL 6029 RAL 6034 RAL 5015 RAL 5023 RAL 5010 RAL 8025 RAL 7035 RAL 9006 RAL 7036 RAL 7016 RAL 9005



BANCOS EN MADERA Y ACERO

WOODEN AND STEEL BENCHES / BANCS EN BOIS ET ACIER / BANCOS EM MADEIRA E AÇO



BANCOS EN MADERA Y ACERO WOODEN AND STEEL BENCHES BANCS EN BOIS ET ACIER BANCOS EM MADEIRA E AÇO

Travesaño de refuerzo.
Reinforcement crossbar.
Barre transversale de renfort.
Barra de reforço.

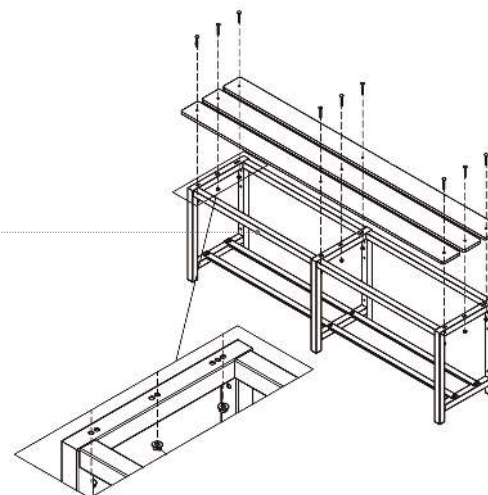

Rigidez

Rigidity/Rigidité/Rigidez



CARACTERÍSTICAS / CHARACTERISTICS / CARACTERISTIQUES / CARACTERISTICAS



RAL 7035

Estándar: Gris RAL 7035.

Standard: Grey RAL 7035.
Standard: Gris RAL 7035.
Padrão: Cinza RAL 7035.



Chasis en tubo de acero.

Steel tube chassis.
Châssis en tube d'acier.
Construção em tubo de aço soldado.



No es recomendable para espacios húmedos.

Not recommended for wet spaces.
Pas recommandé pour les environnements humides.
Nao é recomendável para lugares com humidade.



Contera regulable en altura.

Adjustable end cap.
Pieds réglables en hauteur.
Pés reguláveis.

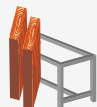

Se sirve desmontado.

Delivered disassembled.
Fourni démonté.
Fornecemos tubo desmontado.



Listones de pino barnizado.

Varnished pine wood slats.
Lattes en pin verni.
Assento de pinheiro envernizado.



Perchas de zamak de triple gancho.

Triple zamak hooks.
Crochets en zamak.
Ganchos triplos de zamak.



Tubos de 30 x 30 mm.
Tubes of 30 x 30 mm.
Tubes de 30 x 30 mm.
Tubos 30 x 30 mm.



Gran resistencia.

High resistance.
Très résistant.
Muito resistente.



Fácil montaje.

Easy assembly.
Montage facile.
Facil montagem.



Microtexturado.

Microtextured.
Microtexturé.
Microtexturado.

OPCIONES / OPTIONS / OPTIONS / OPÇÕES



Fijación a suelo.

Floor fixing.
Fixation au sol.
Fixação piso.



Opción repisa zapatero.

Shoe rack option.
Option lattes repose-chaussures.
Opção sapateiro.

COLORES OPCIONALES CHASIS / OPTIONAL CHASSIS COLOURS / COULEURS POUR CHÂSSIS EN OPTION / CORES CHASSI OPCIONAIS

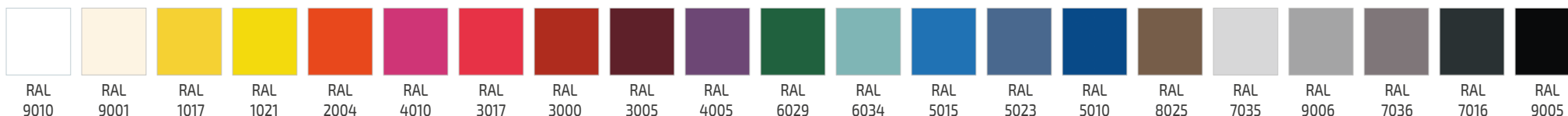

BANCOS EN MADERA Y ACERO

WOODEN AND STEEL BENCHES / BANCS EN BOIS ET ACIER / BANCOS EM MADEIRA E AÇO



BANC-MINI



BANC-1-1500



BANC-1-2000



BANC-2-1500



BANC-3-1500-DC



BANC-4-1500



BANCOS EN MADERA Y ACERO

WOODEN AND STEEL BENCHES / BANCS EN BOIS ET ACIER / BANCOS EM MADEIRA E AÇO

SERIE BANC-1

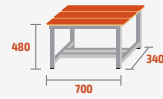

BANC-MINI
COD: 79004
8kg · 0,11m³

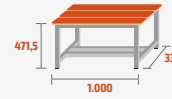

BANC-1-1000
COD: 79010
9,5kg · 0,16m³

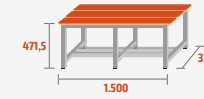

BANC-1-1500
COD: 79001
14kg · 0,23m³

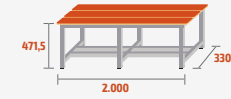

BANC-1-2000
COD: 97020
18kg · 0,31m³

SERIE BANC-2

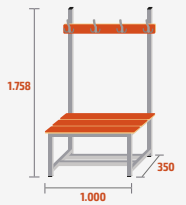

BANC-2-1000
COD: 79012
16kg · 0,23m³ · 4 ↓

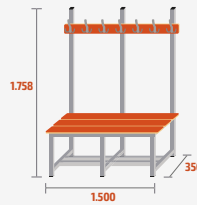

BANC-2-1500
COD: 79013
24kg · 0,3m³ · 7 ↓

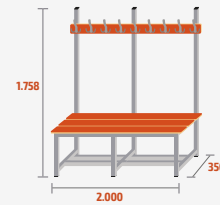

BANC-2-2000
COD: 79014
29kg · 0,31m³ · 9 ↓

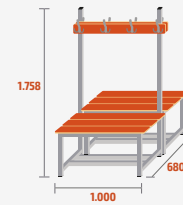

BANC-2-1000-DC
COD: 79212
28kg · 0,46m³ · 8 ↓

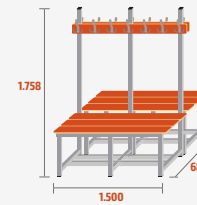

BANC-2-1500-DC
COD: 79213
42kg · 0,6m³ · 14 ↓

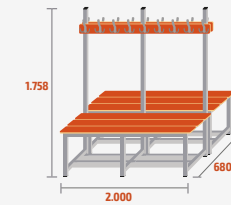

BANC-2-2000-DC
COD: 79214
52kg · 0,62m³ · 18 ↓

SERIE BANC-3

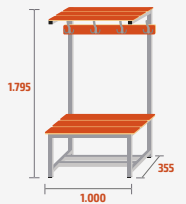

BANC-3-1000
COD: 79022
21,5kg · 0,28m³ · 4 ↓

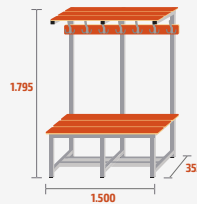

BANC-3-1500
COD: 79023
28,5kg · 0,36m³ · 7 ↓

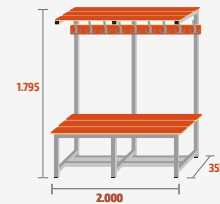

BANC-3-2000
COD: 79024
33,5kg · 0,45m³ · 9 ↓



BANC-3-1000-DC
COD: 79222
37kg · 0,48m³ · 8 ↓

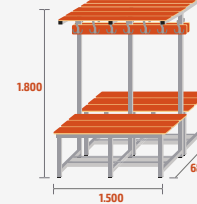

BANC-3-1500-DC
COD: 79223
51kg · 0,62m³ · 14 ↓

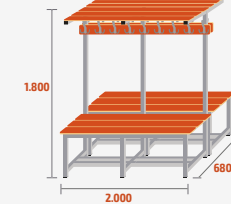

BANC-3-2000-DC
COD: 79224
61kg · 0,64m³ · 18 ↓

SERIE BANC-4

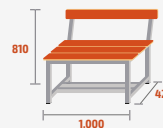

BANC-4-1000
COD: 79300
11,5kg · 0,34m³

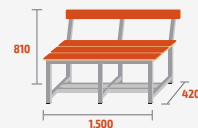

BANC-4-1500
COD: 79325
16,5kg · 0,51m³

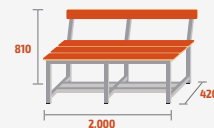

BANC-4-2000
COD: 79350
20,5kg · 0,68m³

BANCOS EN MELAMINA

MELAMINE BENCHES / BANCS EN MÉLAMINE / BANCOS A MADEIRA DE TOLA



BANC-ME-1000
COD: 79008 · 12kg · 0,19m³

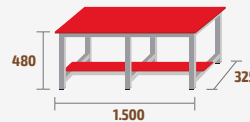

BANC-ME-1500
COD: 79009 · 16,5kg · 0,29m³

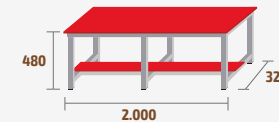

BANC-ME-2000
COD: 79011 · 20,5kg · 0,38m³

CARACTERÍSTICAS / CHARACTERISTICS / CARACTERISTIQUES / CARACTERISTICAS



Chasis en tubo de acero.
Steel tube chassis.
Fabriqué en tube d'acier.
Construção em tubo de aço soldado.



Lamas de melamina de 19 mm.
Panels in melamine of 19 thickness.
Lattes en mélamine de 19 mm.
Lamas de madeira de tola de 19 mm.



MICRO TEX
Microtexturado.
Microtextured.
Microtexturé.
Microtexturado.



Contera regulable en altura.
Adjustable end cap.
Pieds avec capuchons en plastique
avec réglage en hauteur.
Pés reguláveis.



No es recomendable para espacios húmedos.
Not recommended for wet spaces.
Pas recommandé pour les environnements humides.
Nao é recomendável para lugares com humidade.



Fácil montaje.
Easy assembly.
Montage facile.
Facil montagem.

OPCIONES / OPTIONS / OPÇÕES



Fijación a suelo.
Floor fixing.
Fixation au sol.
Fixação piso.

COLORES OPCIONALES CHASIS / OPTIONAL CHASSIS COLOURS / COULEURS POUR CHÂSSIS EN OPTION / CORES CHASSI OPCIONAIS

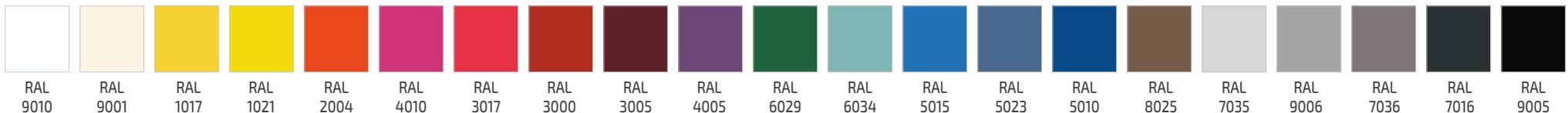













COLORES OPCIONALES MELAMINA / OPTIONAL MELAMINE COLOURS / COULEURS MÉLAMINE OPTION / CORES MADEIRA DE TOLA OPCIONAIS





CARACTERÍSTICAS / CHARACTERISTICS / CARACTERISTIQUES / CARACTERISTICAS

 <p>Estándar: Gris RAL 7035. Standard: Grey RAL 7035. Standard: Gris RAL 7035. Padrão: Cinza RAL 7035.</p>	 <p>Se sirve desmontado. Delivered disassembled. Fourni démonté. Fornecemos tubo desmontado.</p>	 <p>Gran resistencia. High resistance. Très résistant. Muito resistente.</p>
 <p>Chasis en tubo de acero. Steel tube chassis. Châssis en tube d'acier. Construção em tubo de aço soldado.</p>	 <p>Tubos de 30 x 30 mm. Tubes of 30 x 30 mm. Tubes de 30 x 30 mm. Tubos 30 x 30 mm.</p>	 <p>Fácil montaje. Easy assembly. Montage facile. Facil montagem.</p>
 <p>Tablero fenólico de 12 mm de espesor. Seat made of HPL in 12 mm thickness. Lattes en stratifié compact épaisseur 12 mm Assento em fenólico de 12 mm de espessura.</p>	 <p>Perchas de zamak de triple gancho. Triple zamak hooks. Crochets en zamak. Ganchos tripos de zamak.</p>	 <p>Microtexturado. Microtextured. Microtexturé. Microtexturado.</p>
 <p>Tablero compacto de resinas fenólicas. HPL panel, made of phenolic resins. Stratifié compact. Resinas fenólicas.</p>	 <p>Contera regulable en altura. Adjustable end cap. Pieds avec capuchons en plastique avec réglage en hauteur. Pés reguláveis.</p>	 <p>Pintado en Epoxi. Painted in Epoxy. Peinture en epoxi. Pintura em epoxi.</p>

OPCIONES / OPTIONS / OPTIONS / OPÇÕES

 <p>Fijación a suelo. Floor fixing. Fixation au sol. Fixação piso.</p>
 <p>Opción repisa zapatero. Shoe rack option. Option latte repose-chaussures. Opção sapateiro.</p>
 <p>Estructura en acero inoxidable AISI 304. Structure made of stainless steel AISI 304. Structure en acier inoxydable AISI 304. Estrutura em aço inox AISI 304.</p>

COLORES OPCIONALES LAMAS / OPTIONAL SEAT COLOURS / OPTION COULEURS LAMES / CORES FENÓLICO OPCIONAIS

Blanco F-085	Gris claro F-0074	Crema F-0851	Amarillo F-0010	Naranja F-0011	Rosa F-0232	Rojo F-0210	Verde claro F-0725	Verde oscuro F-6901	Turquesa F-2478	Burdeos F-0318	Azul claro F-0718	Azul oscuro F-0717	Aluminio F-0193	Gris oscuro F-0077	Negro F-0080	Madera Clara FM-100	Madera oscura FM-200	Wengue FF-405

CHASIS EN TUBO DE ACERO / STEEL TUBE CHASSIS / STRUCTURE EN TUBE D'ACIER SOUDÉ / ESTRUTURA EM TUBO DE AÇO SOLDADO



Chasis en tubo de acero.
Steel tube chassis.
Châssis en tube d'acier.
Construção em tubo de aço soldado.

RAL 9010	RAL 9001	RAL 1017	RAL 1021	RAL 2004	RAL 4010	RAL 3017	RAL 3000	RAL 3005	RAL 4005	RAL 6029	RAL 6034	RAL 5015	RAL 5023	RAL 5010	RAL 8025
RAL 7035	RAL 9006	RAL 7036	RAL 7016	RAL 9005											

**Resistente al agua / Waterproof /
Imperméable à l'eau / Resistente al água**

CHASIS EN ACERO INOXIDABLE / STRUCTURE MADE OF STAINLESS STEEL STRUCTURE EN ACIER INOXYDABLE / ESTRUTURA EM AÇO INOX



Estructura en acero inoxidable AISI 304.
Structure made of stainless steel AISI 304.
Structure en acier inoxydable AISI 304.
Estrutura em aço inox AISI 304.



Tornillería en acero inoxidable.
Screws in stainless steel.
Visserie en acier inoxydable.
Parafusos em aço inox.



Recomendado para ambientes húmedos. Resistente al agua.
Recommended for wet areas. Waterproof.
Récommandé pour les environnements humides.
Recomendado para lugares com humidade. Resistente al água.

**Resistente al agua / Waterproof /
Imperméable à l'eau / Resistente al água**





BANCOS EN FENÓLICO

HPL BENCHES / BANCS EN STRATIFIÉ MASSIF / BANCOS EM FORMICA



BANC-PARED-1500-FEN



BANC-1-1000-FEN



BANC-1-1000-FEN
Con repisa zapatero/with shoe rack
Avec étagère pour chaussures/Com sapateiro.



BANC-1-1000-FEN-INOX



BANC-1-1500-FEN



BANC-2-1000-FEN



BANC-2-1500-FEN



BANC-3-1500-FEN-DC

BANCOS EN FENÓLICO

HPL BENCHES / BANCS EN STRATIFIÉ MASSIF / BANCOS EM FORMICA

SERIE BANC-PARED



BANC-PARED-1000-FEN
COD: 79510
9kg · 0,13m³



BANC-PARED-1500-FEN
COD: 79511
15kg · 0,2m³

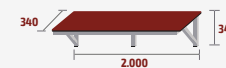

BANC-PARED-2000-FEN
COD: 79512
21kg · 0,26m³

SERIE BANC-1

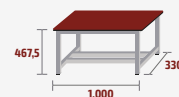

BANC-1-1000-FEN
COD: 79501
12kg · 0,16m³

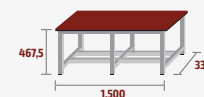

BANC-1-1500-FEN
COD: 79502
18kg · 0,27m³

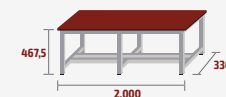

BANC-1-2000-FEN
COD: 79503
24kg · 0,33m³

SERIE BANC-2

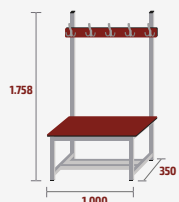

BANC-2-1000-FEN
COD: 79504
24kg · 0,23m³ · 5 ↓

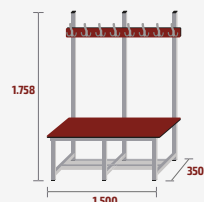

BANC-2-1500-FEN
COD: 79505
32kg · 0,30m³ · 8 ↓

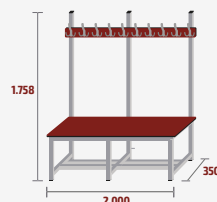

BANC-2-2000-FEN
COD: 79506
37kg · 0,31m³ · 10 ↓

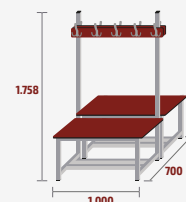

BANC-2-1000-FEN-DC
COD: 79554
48kg · 0,46m³ · 10 ↓

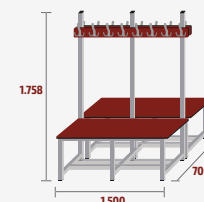

BANC-2-1500-FEN-DC
COD: 79555
64kg · 0,6m³ · 16 ↓

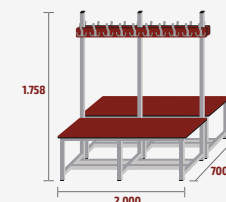

BANC-2-2000-FEN-DC
COD: 79556
74kg · 0,62m³ · 20 ↓

SERIE BANC-3

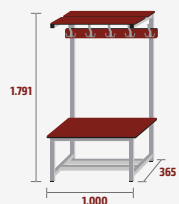

BANC-3-1000-FEN
COD: 79507
31,5kg · 0,23m³ · 5 ↓

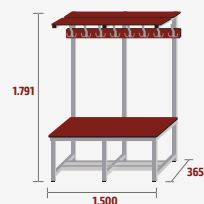

BANC-3-1500-FEN
COD: 79508
38,5kg · 0,30m³ · 8 ↓

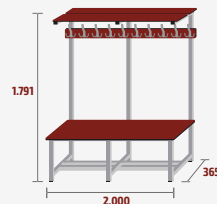

BANC-3-2000-FEN
COD: 79509
43,5kg · 0,31m³ · 10 ↓

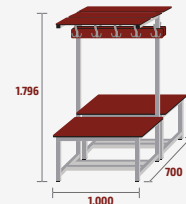

BANC-3-1000-FEN-DC
COD: 79557
63kg · 0,46m³ · 10 ↓

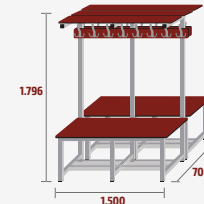

BANC-3-1500-FEN-DC
COD: 79558
77kg · 0,6m³ · 16 ↓

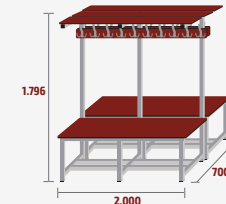

BANC-3-2000-FEN-DC
COD: 79559
87kg · 0,62m³ · 20 ↓

SERIE BANC-1-INOX



BANC-1-1000-FEN-INOX
 COD: 79500
 12kg · 0,16m³



BANC-1-1500-FEN-INOX
 COD: 79515
 18kg · 0,24m³



BANC-1-2000-FEN-INOX
 COD: 79520
 24kg · 0,33m³

SERIE BANC-2-INOX

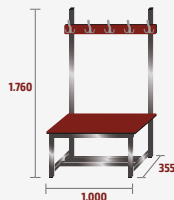

BANC-2-1000-FEN-INOX
 COD: 79521
 24kg · 0,23m³ · 5 ↓

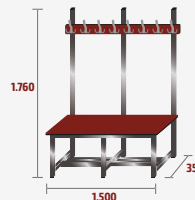

BANC-2-1500-FEN-INOX
 COD: 79522
 32kg · 0,30m³ · 8 ↓

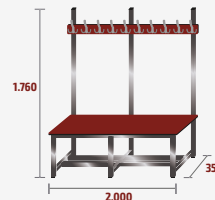

BANC-2-2000-FEN-INOX
 COD: 79523
 37kg · 0,31m³ · 10 ↓

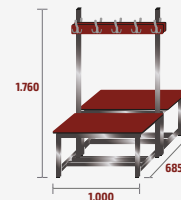

BANC-2-1000-DC-FEN-INOX
 COD: 70825
 28kg · 0,46m³ · 8 ↓

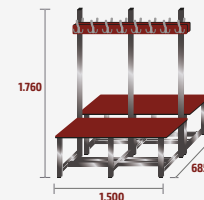

BANC-2-1500-DC-FEN-INOX
 COD: 70826
 42kg · 0,6m³ · 14 ↓

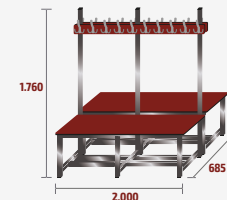

BANC-2-2000-DC-FEN-INOX
 COD: 70827
 52kg · 0,62m³ · 18 ↓

SERIE BANC-3-INOX

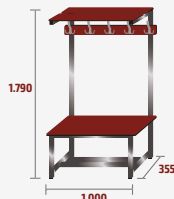

BANC-3-1000-FEN-INOX
 COD: 79524
 31,5kg · 0,23m³ · 5 ↓

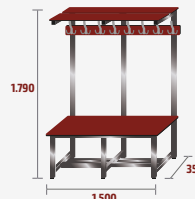

BANC-3-1500-FEN-INOX
 COD: 79525
 38,5kg · 0,30m³ · 8 ↓

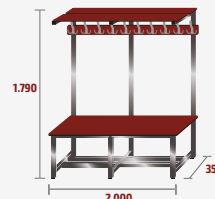

BANC-3-2000-FEN-INOX
 COD: 79526
 43,5kg · 0,31m³ · 10 ↓

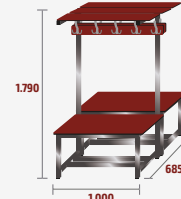

BANC-3-1000-DC-FEN-INOX
 COD: 70823
 63kg · 0,46m³ · 10 ↓

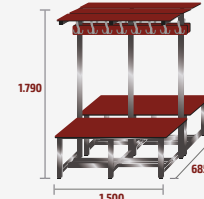

BANC-3-1500-DC-FEN-INOX
 COD: 70824
 77kg · 0,6m³ · 16 ↓

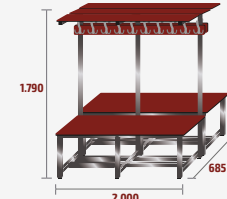

BANC-3-2000-DC-FEN-INOX
 COD: 70809
 87kg · 0,62m³ · 20 ↓



CARACTERÍSTICAS / CHARACTERISTICS / CARACTERISTIQUES / CARACTERISTICAS



Fabricado en PVC.
 Manufactured in PVC.
 Fabriqué en PVC.
 Fabricação em PVC.

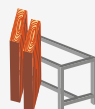

Se sirve desmontado.
 Delivered disassembled.
 Fourni démonté.
 Fornecemos tubo desmontado.



Fácil montaje.
 Easy assembly.
 Montage facile.
 Facil montagem.



Tubos de 55 x 55 mm.
 Tubes of 55 x 55 mm.
 Tubes de 55 x 55 mm.
 Tubos 55 x 55 mm.



Recomendado para ambientes húmedos. Resistente al agua.
 Recommended for wet areas. Waterproof.
 Recommandé pour les environnements humides.
 Recomendado para lugares com humidade. Resistente al água.

COLORES / COLOURS / COULEURS / CORES

TUBO / TUBE / TUBE / TUBO



GRIS AZUL BLANCO

TAPONES / CAPS / BOUCHONS / TAMPA



NEGRO MARRÓN AZUL



BANC-PARED-PVC-2000



BANC-1-PVC-1000



BANC-1-PVC-1000-DC



BANC-3-PVC-1500



BANC-3-PVC-2000-DC



SERIE BANC-PARED

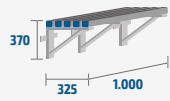

BANC-PARED-PVC-1000
 COD: 79114
 10kg · 0,12m³

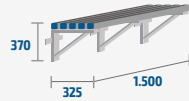

BANC-PARED-PVC-1500
 COD: 79115
 12kg · 0,18m³

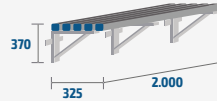

BANC-PARED-PVC-2000
 COD: 79116
 15kg · 0,24m³

SERIE BANC-1

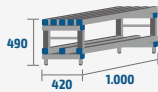

BANC-1-PVC-1000
 COD: 79101
 8kg · 0,20m³

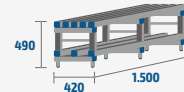

BANC-1-PVC-1500
 COD: 79102
 10kg · 0,30m³

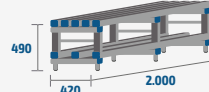

BANC-1-PVC-2000
 COD: 79103
 13kg · 0,41m³

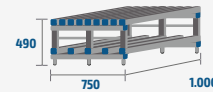

BANC-1-PVC-1000-DC
 COD: 79111
 15kg · 0,37m³

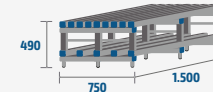

BANC-1-PVC-1500-DC
 COD: 79112
 18kg · 0,55m³

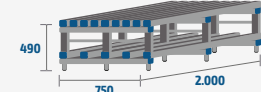

BANC-1-PVC-2000-DC
 COD: 79113
 24kg · 0,73m³

SERIE BANC-3

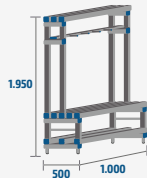

BANC-3-PVC-1000
 COD: 79131
 17kg · 0,3m³ · 4 d

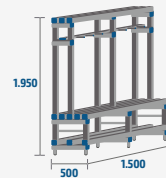

BANC-3-PVC-1500
 COD: 79132
 22kg · 0,45m³ · 6 d

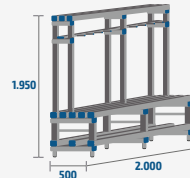

BANC-3-PVC-2000
 COD: 79133
 28kg · 0,61m³ · 8 d

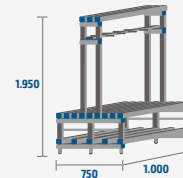

BANC-3-PVC-1000-DC
 COD: 79162
 32kg · 0,5m³ · 8 d

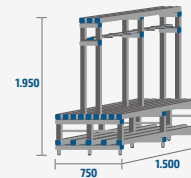

BANC-3-PVC-1500-DC
 COD: 79164
 39kg · 0,75m³ · 12 d

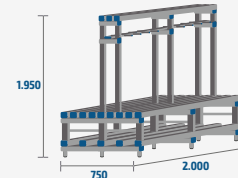

BANC-3-PVC-2000-DC
 COD: 79166
 52kg · 1,02m³ · 16 d

COLGADORES, PERCHEROS Y REPISAS

WALL COAT HOOKS / PATERES / CABIDES

ACERO / STEEL / ACIER / AÇO



COLG-4-400
COD: 79950



COLG-5-600
COD: 79955



COLG-6-900
COD: 79960

MADERA Y ACERO / WOODEN AND STEEL / BOIS ET ACIER / MADEIRA E AÇO



COLG-1-1000
COD: 79910



COLG-2-1500
COD: 79915



COLG-3-2000
COD: 79920

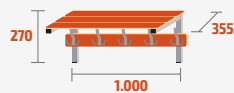

REP-MAD-1000
COD: 79911 · 7kg · 0,11m³

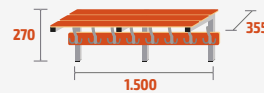

REP-MAD-1500
COD: 79916 · 10kg · 0,16m³

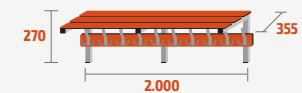

REP-MAD-2000
COD: 79921 · 13kg · 0,22m³

COLGADORES, PERCHEROS Y REPISAS

WALL COAT HOOKS / PATERES / CABIDES

FENÓLICO / HPL / STRATIFIÉ MASSIF / FORMICA



PER-FEN-1000
COD: 79930 · 3kg · 0,009m³



PER-FEN-1500
COD: 79931 · 5kg · 0,013m³



PER-FEN-2000
COD: 79932 · 8kg · 0,018m³

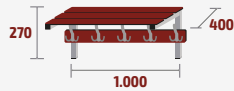

REP-FEN-1000
COD: 79940 · 8kg · 0,11m³



REP-FEN-1500
COD: 79941 · 11kg · 0,16m³

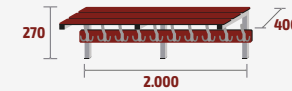

REP-FEN-2000
COD: 79942 · 14kg · 0,22m³

COLORES OPCIONALES FENÓLICO / OPTIONAL HPL COLOURS / COULEURS STRATIFIÉ MASSIF OPTION / CORES FORMICA OPCIONAIS

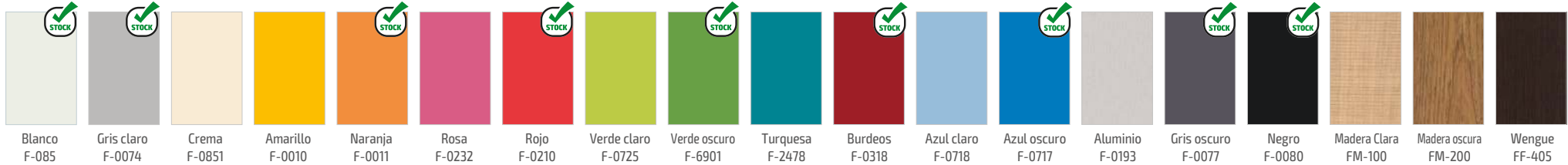



MESAS Y BANCOS PARA COMEDOR

TABLES AND BENCHES FOR DINING ROOMS / TABLES ET BANCS POUR SALLE À MANGER / MESAS E BANCOS PARA SALA



CARACTERÍSTICAS / CHARACTERISTICS / CARACTERISTIQUES / CARACTERISTICAS



Gran resistencia.
High resistance.
Très résistant.
Muito resistente.



Fácil limpieza.
Easy cleaning.
Nettoyage facile.
Fácil limpeza.



Sin montaje.
Without assembly.
Sans montage.
Sem montagem.



Tubos de 30 x 30 mm.
Tubes of 30 x 30 mm.
Tubes de 30 x 30 mm.
Tubos 30 x 30 mm.



Plegable.
Foldable.
Pliant.
Plegavel.



Fácil montaje.
Easy assembly.
Montage facile.
Facil montagem.

CHASIS EN ACERO INOXIDABLE / STRUCTURE MADE OF STAINLESS STEEL STRUCTURE EN ACIER INOXYDABLE / ESTRUTURA EM AÇO INOX



INOX Estructura en acero inoxidable AISI 304.
Structure made of stainless steel AISI 304.
Structure en acier inoxydable AISI 304.
Estrutura em aço inox AISI 304.



INOX Tornillería en acero inoxidable.
Screws in stainless steel.
Visserie en acier inoxydable.
Parafusos em aço inox.

CHASIS EN TUBO DE ACERO / STEEL TUBE CHASSIS / STRUCTURE EN TUBE D'ACIER SOUDÉ / ESTRUTURA EM TUBO DE AÇO SOLDADO



Chasis en tubo de acero.
Steel tube chassis.
Châssis en tube d'acier.
Construção em tubo de aço soldado.



RAL 7035

Estándar: Gris RAL 7035.
Standard: Grey RAL 7035.
Standard: Gris RAL 7035.
Padrão: Cinza RAL 7035.



MICRO TEX Microtexturado.
Microtextured.
Microtexturé.
Microtexturado.

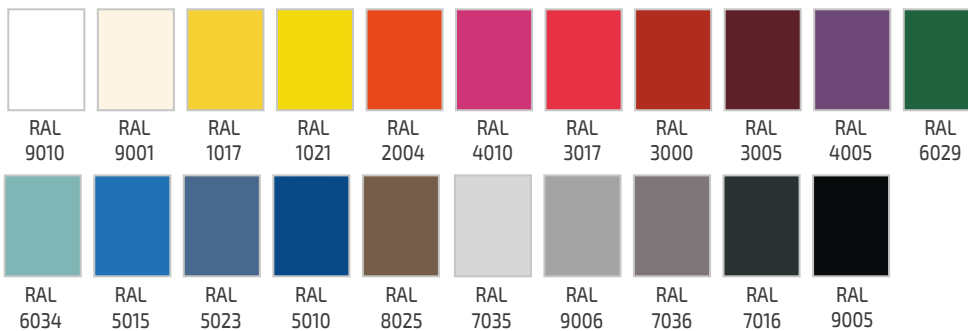

LAMAS FENÓLICAS / HPL SLATS / LATTES EN STRATIFIÉ COMPACT / LAMAS EM FENÓLICO



Tablero compacto de resinas fenólicas.
HPL panel, made of phenolic resins.
Stratifié compact.
Resinas fenólicas.

**Resistente al agua / Waterproof /
Imperméable à l'eau / Resistente al água**



Lamas de tablero fenólico de 12 mm de espesor.
Seats made of HPL slats of 12 mm thickness.
Lattes en stratifié compact épaisseur 12 mm
Assento em fenólico de 12 mm de espessura.



LAMAS MELAMINA / MELAMINE SLATS / LATTES EN MÉLAMINE / LAMAS EM MADEIRA DE TOLA



Lamas de melamina de 19 mm.
Panels in melamine of 19 thickness.
Lattes en mélamine de 19 mm.
Lamas de madeira de tola de 19 mm.

**Resistente al agua / Waterproof /
Imperméable à l'eau / Resistente al água**

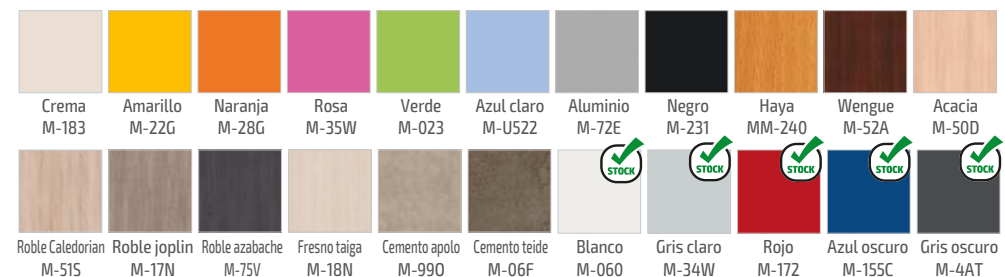

MESAS Y BANCOS PARA COMEDOR



TABLES AND BENCHES FOR DINING ROOMS / TABLES ET BANCS POUR SALLE À MANGER / MESAS E BANCOS PARA SALA

ACERO FENÓLICO
STEEL HPL
ACIER STRATIFIÉ COMPACT
AÇO FENÓLICO

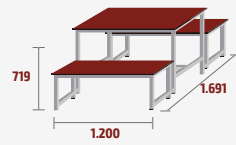

MB-HF12

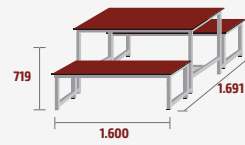
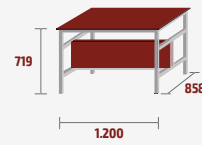

MB-HF16

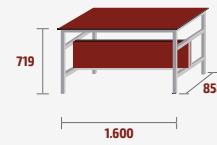

INOX FENÓLICO
INOX HPL
INOX STRATIFIÉ COMPACT
INOX FENÓLICO



MB-IF12

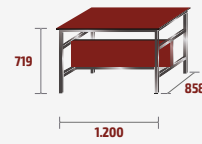

MB-IF16

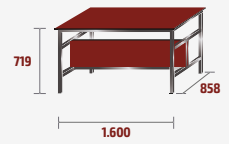

ACERO MELAMINA
STEEL MELAMINE
ACIER MÉLAMINE
AÇO MADEIRA DE TOLA

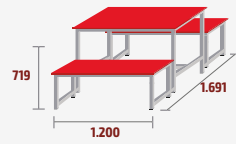

MB-HM12

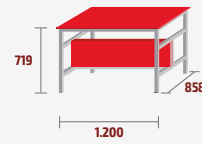

MB-HM16

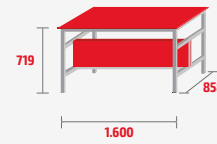

INOX MELAMINA
INOX MELAMINE
INOX MÉLAMINE
INOX MADEIRA DE TOLA



MB-IM12

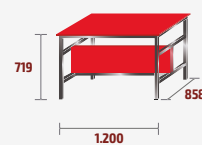

MB-IM16

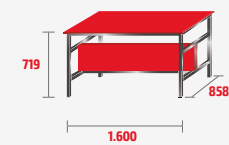

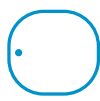

TAQUILLAS PLÁSTICO

PLASTIC LOCKERS / VESTIAIRES EN PLÁSTICO / ARMÁRIOS EM PLÁSTICO



SERIE PV

1 Puerta
Door
Porte
Porta



SERIE PT

2 Puertas
Doors
Portes
Portas



SERIE PM

3 Puertas
Doors
Portes
Portas



SERIE PC

4 Puertas
Doors
Portes
Portas



SERIE PB

6 Puertas
Doors
Portes
Portas



SERIE PZ

8 Puertas
Doors
Portes
Portas



SERIE PE

Armario material de limpieza
Cleaning material locker
Armoire pour materiel de nettoyage
Armario de limpeza

CARACTERÍSTICAS / CHARACTERISTICS / CARACTERISTIQUES / CARACTERISTICAS



Fabricado en PVC.
Manufactured in PVC.
Fabriqué en PVC.
Fabricação em PVC.



Sin montaje.
Without assembly.
Sans montage.
Sem montagem.



Fácil instalación de bandejas.
Easy installation of the shelves.
Montage facile des tablettes.
Facil motagem des tablettes.



Gran resistencia.
High resistance.
Très résistant.
Muito resistente.



Cerradura de llave.
Standard key lock.
Serrure standard à clé.
Fechadura standard de chave.



Pata regulable en altura.
Adjustable end cap in height.
Pieds réglables en hauteur.
Pés reguláveis em altura.



Material antibacteriano.
Antibacterial material.
Matériel antibactérien.
Material antibacteriano.



Fácil limpieza.
Easy cleaning.
Nettoyage facile.
Fácil limpeza.



Cuerpo y puertas blanco.
White body and doors.
Corp et portes blanc.
Corpo e portas branco.

▶ 18mm ◀

Espesores.
Thickness.
Épaisseurs.
Espessura.

▶ 2,5mm ◀

Trasera.
Back panel.
Partie arrière.
Reforço.



Recomendado para ambientes húmedos. Resistente al agua.
Recommended for wet areas. Waterproof.
Récommandé pour les environnements humides.
Recomendado para lugares com humidade. Resistente à água.

OPCIONES / OPTIONS / OPTIONS / OPÇÕES



Sobretecho inclinado.
Slope top.
Toit incliné.
Sobreteto con pequena inclinação.



Zócalo PVC.
PVC plinth.
Socle PVC.
Soclo PVC.



Divisoria vertical.
Vertical center partition.
Séparation verticale.
Divisória vertical.

COLORES OPCIONALES PARA LA PERCHA, COLGADORES Y RESPIRADERO / OPTIONAL COLOURS FOR THE COAT ROD, HOOKS AND VENTILATION OPENINGS / COULEURS EN OPTION POUR LA TRINGLE PORTE CINTRES, LE CROCHET ET LE VOLET D'ÉRÉRATION / OPÇÕES CORES PARA A BARRA O CABIDE E A VENTILAÇÃO DAS PORTAS.



SERIE PV

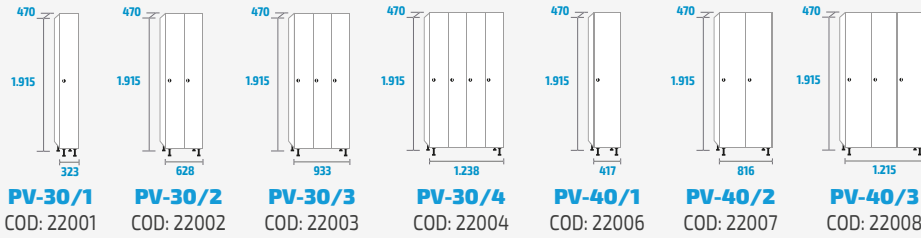

PV-30/1 COD: 22001
PV-30/2 COD: 22002
PV-30/3 COD: 22003
PV-30/4 COD: 22004
PV-40/1 COD: 22006
PV-40/2 COD: 22007
PV-40/3 COD: 22008

SERIE PC

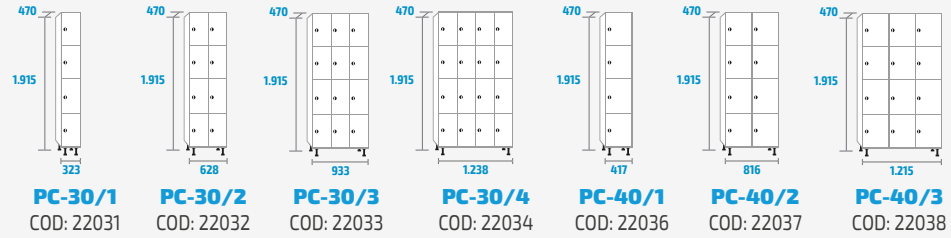

PC-30/1 COD: 22031
PC-30/2 COD: 22032
PC-30/3 COD: 22033
PC-30/4 COD: 22034
PC-40/1 COD: 22036
PC-40/2 COD: 22037
PC-40/3 COD: 22038

SERIE PT

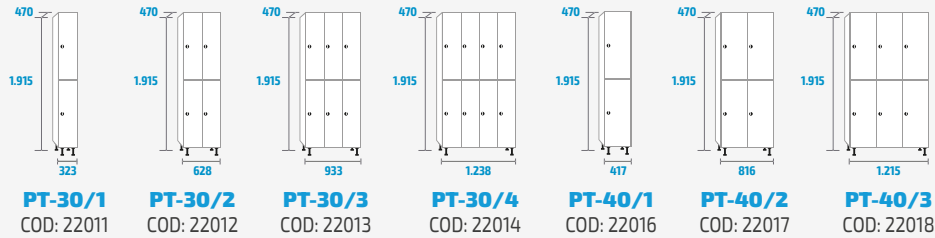

PT-30/1 COD: 22011
PT-30/2 COD: 22012
PT-30/3 COD: 22013
PT-30/4 COD: 22014
PT-40/1 COD: 22016
PT-40/2 COD: 22017
PT-40/3 COD: 22018

SERIE PB

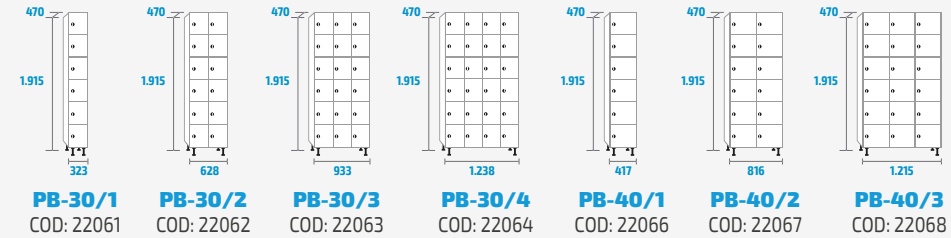

PB-30/1 COD: 22061
PB-30/2 COD: 22062
PB-30/3 COD: 22063
PB-30/4 COD: 22064
PB-40/1 COD: 22066
PB-40/2 COD: 22067
PB-40/3 COD: 22068

SERIE PM

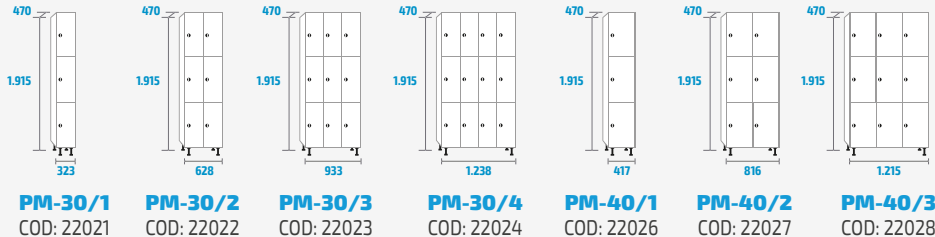

PM-30/1 COD: 22021
PM-30/2 COD: 22022
PM-30/3 COD: 22023
PM-30/4 COD: 22024
PM-40/1 COD: 22026
PM-40/2 COD: 22027
PM-40/3 COD: 22028

SERIE PZ

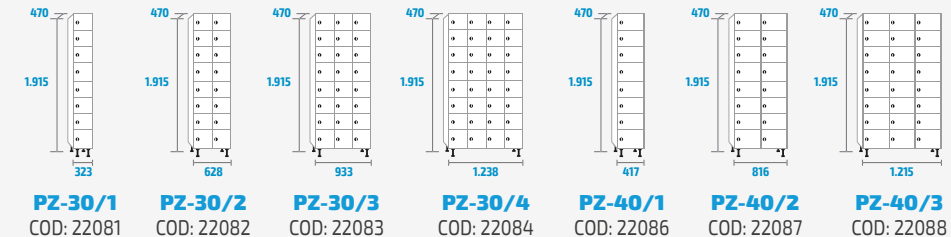

PZ-30/1 COD: 22081
PZ-30/2 COD: 22082
PZ-30/3 COD: 22083
PZ-30/4 COD: 22084
PZ-40/1 COD: 22086
PZ-40/2 COD: 22087
PZ-40/3 COD: 22088

SISTEMAS DE APERTURA / OPENING SYSTEM / SYSTÈMES D'OUVERTURE / SISTEMA DE ABERTURA

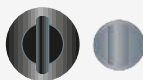

Pomo en poliamida / metálico.
 Padlockable polyamide Lock / metallic Lock.
 Serrure à porte cadenas en polyamide/métallique
 Fechadura de cadeado em poliamida / metal.



Tirador metálico.
 Metal handle.
 Poignée en métal.
 Cabo de metal.



Cerradura de combinación y llave de emergencia.
 Manual combination lock with emergency key.
 Serrure à combinaison de 4 chiffres et clé de secours.
 Fechadura de combinação e chave de emergência.



Cerradura de resbalón con bombillo extraíble y llave extractora.
 Latch operated lock with removable cylinder and master key.
 Serrure à fermeture par glissement avec cylindre extractible et clé passe.
 Fechadura de segurança com possibilidade de tirar o cilindro e chave mestre.



Monedero con moneda retornable/con cajetín depósito.
 Coin-operated Lock with coin-return/collect box.
 Monnayeur avec monnaie retornable/tirelire.
 Moedeiro moeda retornável/caixinha.

SERIE PE

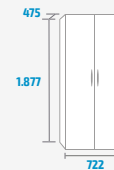

PE-70
 COD: 22100





ARMARIOS EN RESINA DE POLIPROPILENO

POLYPROPYLENE RESIN CABINETS / ARMOIRES EN RESINE DE POLYPROPILENE / ARMÁRIOS EM RESINA DE POLIPROPILENE



CARACTERÍSTICAS / CHARACTERISTICS / CARACTERISTIQUES / CARACTERISTICAS



Se sirve desmontado.
Delivered disassembled.
Fourni démonté.
Fornecemos tubo desmontado.



Color beige.
Colour beige.
Couleur beige.
Cor bege.



Fácil limpieza.
Easy cleaning.
Nettoyage facile.
Fácil limpeza.



Gran resistencia.
High resistance.
Très résistant.
Muito resistente.



Tablero de resina de polipropileno.
Panel made of polypropylene.
Panneau en résine de polypropylène.
Painel de resina de polipropilene.



Recomendado para ambientes húmedos. Resistente al agua.
Recommended for wet areas. Waterproof.
Recommandé pour les environnements humides.
Recomendado para lugares com humidade. Resistente al água.

ARMARIOS EN RESINA DE POLIPROPILENO

POLYPROPYLENE RESIN CABINETS / ARMOIRES EN RESINE DE POLYPROPYLENE / ARMÁRIOS EM RESINA DE POLIPROPILENO

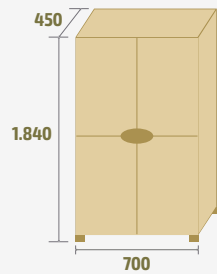

RP-1
COD: 99101
19kg · 0,22m³

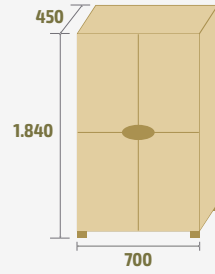

RP-2
COD: 99102
19kg · 0,22m³

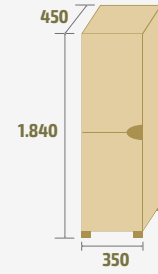

RP-3
COD: 99103
14kg · 0,14m³

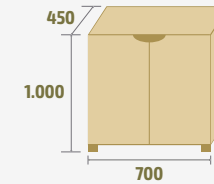

RP-4
COD: 99104
12kg · 0,14m³

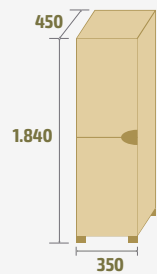

RP-5
COD: 99105
16kg · 0,14m³

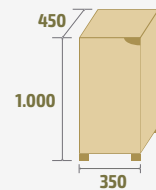

RP-6
COD: 99106
9kg · 0,8m³

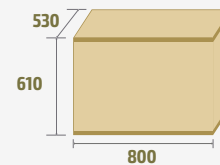

RP-7
COD: 99107
9kg · 1,0m³

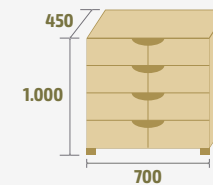

RP-8
COD: 99108
9kg · 1,0m³

CERRADURAS / LOCKS / SERRURES / FECHADURAS



Cerradura de llave
 MODELO: **CERR**
 CÓDIGO: **90080**



Pomo en poliamida
 MODELO: **PPOL**
 CÓDIGO: **90025**



Pomo metálico (taq. metálica)
 MODELO: **PZAM**
 CÓDIGO: **90062**



Pomo metálico (taq. no metálica)
 MODELO: **PZME**
 CÓDIGO: **90158**



Gancho percha
 MODELO: **GPER**
 CÓDIGO: **99775**



Cerradura amaestrada
 MODELO: **CEAMA**
 CÓDIGO: **90022**



Cerradura aparejada
 MODELO: **CEAPA**
 CÓDIGO: **90041**



Cerradura de combinación
 MODELO: **COMBI4D**
 CÓDIGO: **90520**



Cerradura de moneda
 MODELO: **MC1€**
 CÓDIGO: **90036**



Cajetín depósito
 MODELO: **Cajetín depósito**
 CÓDIGO: **90043**



Cerradura de moneda para marco amarre
 MODELO: **MM1€**
 CÓDIGO: **90038**



Cerradura encastrable
 MODELO: **CERRPLA**
 CÓDIGO: **90065**



Cerradura de falleba
 MODELO: **CFALL**
 CÓDIGO: **90026**



Cerradura de tres puntos
 MODELO: **FALL**
 CÓDIGO: **90050**



Cerradura para candado
 MODELO: **CERRCAN**
 CÓDIGO: **90070**





Kit de cerradura
 MODELO: **KITCE**
 CÓDIGO: **90074**



Cerradura electrónica
 MODELO: **TELEC**
 CÓDIGO: **90072**



Cerradura electrónica
 MODELO: **ELOCK**
 CÓDIGO: **90078**



Cerradura electrónica
 MODELO: **PROXI 2**
 CÓDIGO: **90076**



Cerradura electrónica
 MODELO: **NEXT 1**
 CÓDIGO: **90080**



Cerradura electrónica
 MODELO: **NEXT 2**
 CÓDIGO: **90081**



Cerradura electrónica
 MODELO: **SOLA**
 CÓDIGO: **90082**



Cerradura electrónica
 MODELO: **NEXT 3**
 CÓDIGO: **90095**



Cerradura electrónica
 MODELO: **VERSA KEYPAD**
 CÓDIGO: **40697**



Cerradura electrónica
 MODELO: **VERSA RFID**
 CÓDIGO: **40698**



Cerradura electrónica
 MODELO: **3TECH**
 CÓDIGO: **90126**



Cerradura electrónica
 MODELO: **ORBIT**
 CÓDIGO: **90127**



Cerradura electrónica
 MODELO: **ASPIRE KEYPAD**
 CÓDIGO: **90128**



Cerradura electrónica
 MODELO: **ASPIRE RFID**
 CÓDIGO: **90129**



CHARGING BOXES



CHARGING BOX 12P NEW

12 Puertas
Doors
Portes
Portas







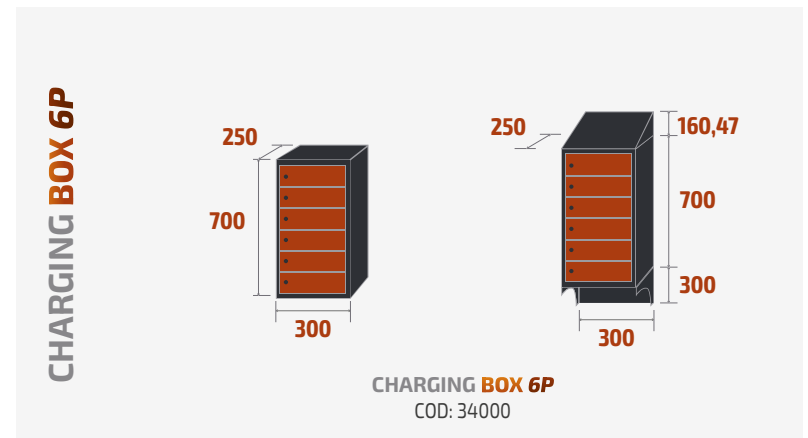
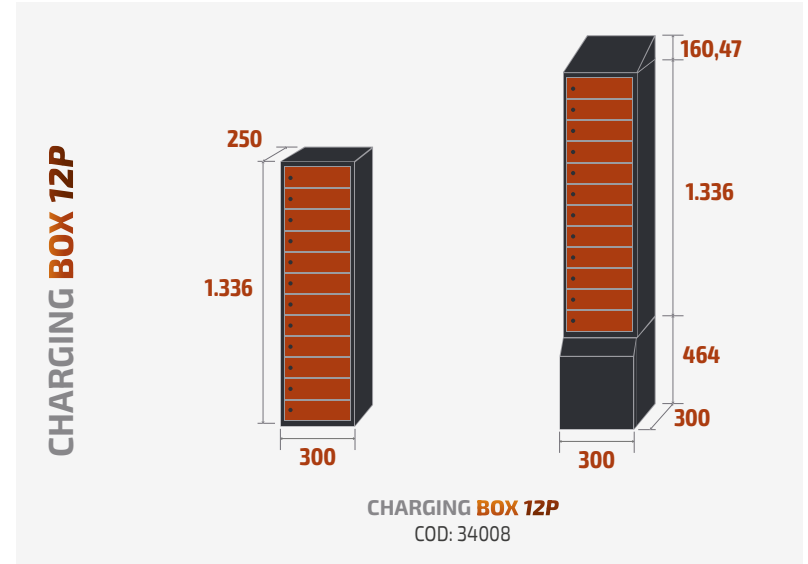





CHARGING BOX 6P NEW

6 Puertas
Doors
Portes
Portas



CARACTERÍSTICAS / CHARACTERISTICS / CARACTERISTIQUES / CARACTERISTICAS

 <p>Sin montaje. Without assembly. Sans montage. Sem montagem.</p>	 <p>Módulos ampliables. Expandable modules. Modules extensibles. Módulos expansíveis.</p>	 <p>Cerradura de llave. Standard key lock. Serrure standard à clé. Fechadura standard de chave.</p>	 <p>Metal. Metal. Metal. Metal.</p>	 <p>Gran resistencia. High resistance. Très résistant. Muito resistente.</p>	 <p>Espesores. Thicknesses. Épaisseurs. Espessura.</p>
 <p>Estructura soldada. Welded structure. Structure soudée. Estrutura soldada.</p>	<p>EPOXI</p> <p>Pintado en Epoxi. Painted in Epoxy. Peinture en epoxi. Pintura em epoxi.</p>	 <p>Conectado a la corriente. Connected to the power. Connecté au courant. Conectado ao poder.</p>	 <p>Cables USB. USB Cables. Câbles USB. Cabos USB.</p>	 <p>No es recomendable para espacios húmedos. Not recommended for wet spaces. Pas recommandé pour les environnements humides. Nao é recomendável para lugares com humidade.</p>	

OPCIONES / OPTIONS / OPTIONS / OPÇÕES

 <p>Numeración. Numeration. Numérotation. Numeração.</p>	 <p>Vinilo. Vinyl. Vinylo. Vinil.</p>	 <p>Autocierre. Self closing. Fermeture automatique. Fechamento automático.</p>
 <p>Sobretecho inclinado. Slope top. Toit incliné. Sobreteto com pequena inclinação.</p>	 <p>Peana a suelo. Base to ground. Châssis au sol. Pé de suporte ao chão.</p>	 <p>Peana a pared. Base to wall. Base pour fixation au mur. Pé de suporte a parede.</p>

CERRADURAS / LOCKS / SERRURES / FECHADURAS

 <p>Cerradura de combinación y llave de emergencia. Manual combination lock with emergency key. Serrure à combinaison de 4 chiffres et clé de secours. Fechadura de combinação e chave de emergência.</p>

COLORES OPCIONALES PUERTAS Y CUERPO / OPTIONAL DOOR AND BODY COLOURS / COULEURS OPTIONNELS POUR CORPS ET PORTES / CORES DE PORTAS E CORPO OPCIONAIS

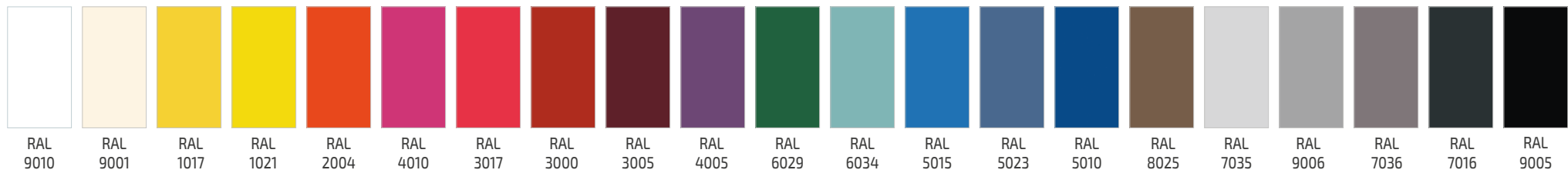

CHARGING BOXES



Sobretecho inclinado.
Slope top.
Toit incliné.
Sobreteito com pequena inclinação.



Vinilo.
Vinyl.
Vinyle.
Vinil.



Cerradura de combinación y llave de emergencia.
Manual combination lock with emergency key.
Serrure à combinaison de 4 chiffres et clé de secours.
Fechadura de combinação e chave de emergência.



Cerradura de llave.
Standard key lock.
Serrure standard à clé.
Fechadura standard de chave.



Peana consigna 12 puertas.
Base left-luggage 12 doors.
Base consigne 12 portes.
Base cacifo 12 portões.

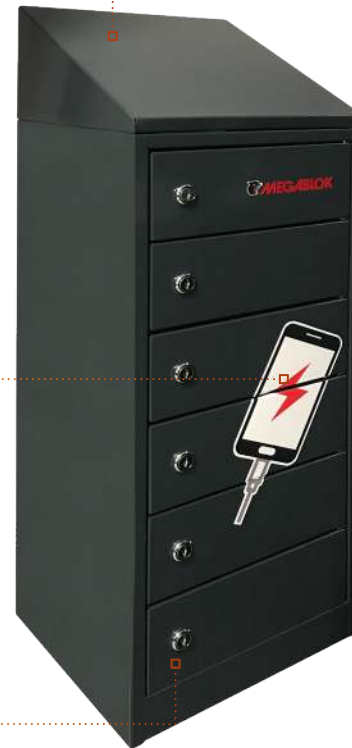

Cables USB.
USB Cables.
Câbles USB.
Cabos USB.



Conectado a la corriente.
Connected to the power.
Connecté au courant.
Conectado ao poder.

CHARGING BOXES



CHARGING CARTS



CHARGING CART DISPOSITIVOS 



CHARGING CART PORTÁTILES 



Interior CHARGING CART DISPOSITIVOS



CARACTERÍSTICAS / CHARACTERISTICS / CARACTERISTIQUES / CARACTERISTICAS

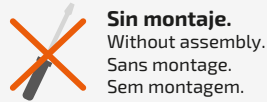

Sin montaje.
Without assembly.
Sans montage.
Sem montagem.



Metal.
Metal.
Metal.
Metal.



Gran resistencia.
High resistance.
Très résistant.
Muito resistente.



Ruedas 360° con freno.
Wheels 360° with brake.
Roues 360° avec frein.
Rodas 360° com freio.



Puerta metálica con cerradura de falleba.
Metal door with espagnolette lock.
Porte en métal avec serrure d'espagnolette.
Porta de metal e fechadura de espagnolette.

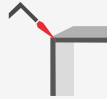

Estructura soldada.
Welded structure.
Structure soudée.
Estrutura soldada.

EPOXI

Pintado en Epoxi.
Painted in Epoxy.
Peinture en epoxi.
Pintura em epoxi.



Conectado a la corriente.
Connected to the power.
Connecté au courant.
Conectado ao poder.



No es recomendable para espacios húmedos.
Not recommended for wet spaces.
Pas recommandé pour les environnements humides.
Nao é recomendável para lugares com humidade.

CHARGING CART DISPOSITIVOS



Bandejas con separadores.
Trays with dividers.
Plateaux avec séparateurs.
Bandejas com divisórias.



1 mm de espesor.
1 mm thickness.
1 mm d'épaisseur.
1 mm de espessura.



Ventilación forzada.
Forced ventilation.
Ventilation forcée.
Ventilação forçada.

CHARGING CART PORTÁTILES



Bandejas sin separadores.
Trays without dividers.
Plateaux sans séparateurs.
Bandejas sem divisórias.



1 mm de espesor.
1 mm thickness.
1 mm d'épaisseur.
1 mm de espessura.



Ventilación forzada.
Forced ventilation.
Ventilation forcée.
Ventilação forçada.



Medidas máximas 17' - 450 mm x 290 mm.
Maximum measures 17' - 450mm x 290mm.
Mesures maximales 17' - 450mm x 290mm.
Medidas máximas 17' - 450mm x 290mm.

CHARGING CART PORTÁTILES ECO



0,8 mm de espesor.
0,8 mm thickness.
0,8 mm d'épaisseur.
0,8 mm de espessura.

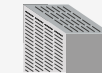

Chapa perforada.
Perforated body.
Corps perforé.
Corpo perfurado.

OPCIONES / OPTIONS / OPTIONS / OPÇÕES



Persiana de PVC.
PVC Rolling door.
Rideau PVC.
Veneziana em PVC.



Barra tirador.
Handle.
Barre de poussée.
Barra tirador.



Cerraduras electrónicas de combinación de 4 dígitos.
Electronic combination locks of 4 digits.
Serrures électroniques à combinaison de 4 chiffres.
Fechaduras electrónicas, combinação de 4 dígitos.



Cerraduras de proximidad.
RFID Locks.
Serrures de proximité.
Fechaduras de proximidade.

OPCIONES / OPTIONS / OPTIONS / OPÇÕES



Barra tirador.
Handle.
Barre de poussée.
Barra tirador.

COLORES OPCIONALES PUERTAS Y CUERPO / OPTIONAL DOOR AND BODY COLOURS / COULEURS EN OPTION POUR CORPS ET PORTES / CORES DE PORTAS E CORPO OPCIONAIS



RAL 9010 RAL 9001 RAL 1017 RAL 1021 RAL 2004 RAL 4010 RAL 3017 RAL 3000 RAL 3005 RAL 4005 RAL 6029 RAL 6034 RAL 5015 RAL 5023 RAL 5010 RAL 8025 RAL 7035 RAL 9006 RAL 7036 RAL 7016 RAL 9005

CHARGING CARTS

CHARGING CART DISPOSITIVOS



CHARGING CART 60D

60 Dispositivos
Devices
Appareils
Aparelhos



CHARGING CART 80D

80 Dispositivos
Devices
Appareils
Aparelhos

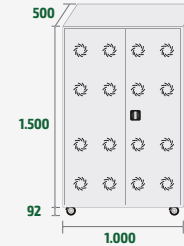

CHARGING CART 160D

160 Dispositivos
Devices
Appareils
Aparelhos

CHARGING CART PORTÁTILES

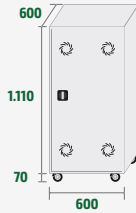

CHARGING CART 18P

18 Dispositivos
Devices
Appareils
Aparelhos

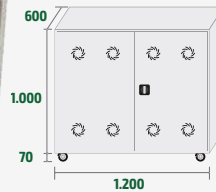

CHARGING CART 30P

30 Dispositivos
Devices
Appareils
Aparelhos

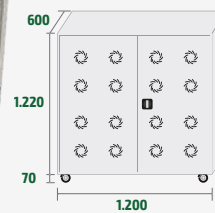

CHARGING CART 40P

40 Dispositivos
Devices
Appareils
Aparelhos

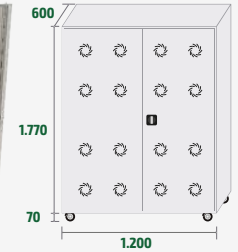

CHARGING CART 60P

60 Dispositivos
Devices
Appareils
Aparelhos

CHARGING CART PORTÁTILES ECO



CHARGING CART 12P

12 Dispositivos
Devices
Appareils
Aparelhos

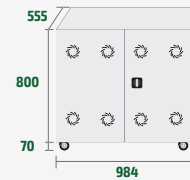

CHARGING CART 24P

24 Dispositivos
Devices
Appareils
Aparelhos



**CHARGING CART
PORTÁTILES**



**CHARGING CART
PORTÁTILES ECO**

<p>Espesor Thickness Épaisseur Espessura</p>	1 mm	0,8 mm
<p>Puertas traseras Back doors Portes arrières Portas traseiras</p>	<input checked="" type="checkbox"/>	<input type="checkbox"/>
<p>Ventilación Ventilation Ventilation Ventilação</p>	<p>Ventilación forzada. Forced ventilation. Ventilation forcée. Ventilação forçada.</p>	<p>Chapa perforada. Perforated panels. Tôle perforée. Chapa perfurada.</p>
<p>Termostato Thermostat Thermostat Termostato</p>	<input checked="" type="checkbox"/>	<input type="checkbox"/>
<p>Autómata Automaton Automatique Automático</p>	<input checked="" type="checkbox"/>	<input type="checkbox"/>
<p>Diferencial eléctrico Electric differential Différentiel électrique Diferencial elétrico</p>	<input checked="" type="checkbox"/>	<input checked="" type="checkbox"/>
<p>Magnetotérmico eléctrico Electrical circuit breaker Magnétothermique électrique Magnetotérmico elétrico</p>	<input checked="" type="checkbox"/>	<input checked="" type="checkbox"/>

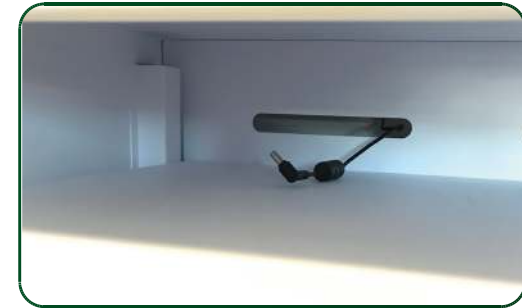

Interior **CHARGING CART 24P**



Interior **CHARGING CART 24P**



Puerta metálica con cerradura de falleba.
Metal door with espagnolette lock.
Porte en métal avec serrure d'espagnolette.
Porta de metal e fechadura de espagnolette.



Barra tirador/Handle/Barre de poussée/Barra tirador.

SERIE MONOBLOK-E

MONOBLOK-E LOCKERS

VESTIAIRES MONOBLOK-E

CACIFOS MONOBLOK-E

Taquilla Monoblok con sistema de carga.

Monoblok locker with charging system.

Vestiaire métallique avec système de chargement.

Cacifo Monoblok com sistema de carregamento.

Ofrece una solución de carga a tus clientes o trabajadores.

Offer a charging solution to your clients or workers.

Offrez une solution de recharge à vos clients ou travailleurs.

Ofereça uma solução de cobrança para seus clientes ou funcionários.

Compatible con las series SV, ST, SM, SC, SP, SB y SZ.

Compatible with SV, ST, SM, SC, SP, SB and SZ series.

Compatible avec les séries SV, ST, SM, SC, SP, SB et SZ.

Compatível com as séries SV, ST, SM, SC, SP, SB e SZ.

Perfecto para entornos académicos y laborales.

Ideal for academic and work environments.

Parfait pour les environnements académiques et de travail.

Perfeito para ambientes acadêmicos e de trabalho.



CARACTERÍSTICAS / CHARACTERISTICS / CARACTERISTIQUES / CARACTERISTICAS

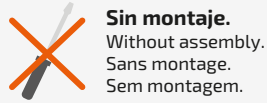

Sin montaje.
Without assembly.
Sans montage.
Sem montagem.



Módulos ampliables.
Expandable modules.
Modules extensibles.
Módulos expansíveis.



Cerradura de llave.
Standard key lock.
Serrure standard à clé.
Fechadura standard de chave.



Espesores.
Thicknesses.
Épaisseurs.
Espessura.



Autocierre.
Self closing.
Fermeture automatique.
Fechamento automático.

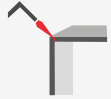

Estructura soldada.
Welded structure.
Structure soudée.
Estrutura soldada.

EPOXI

Pintado en Epoxi.
Painted in Epoxy.
Peinture en epoxi.
Pintura em epoxi.

**MICRO
TEX**

Microtexturado.
Microtextured.
Microtexturé.
Microtexturado.



Metal.
Metal.
Metal.
Metal.



No es recomendable para espacios húmedos.
Not recommended for wet spaces.
Pas recommandé pour les environnements humides.
Nao é recomendável para lugares com humidade.

OPCIONES ELÉCTRICAS / ELECTRICAL OPTIONS / OPTIONS ÉLECTRIQUES / OPÇÕES ELÉTRICAS



Cables USB.
USB Cables.
Câbles USB.
Cabos USB.



Enchufe.
Socket.
Prise électrique.
Plug.



Cables USB y enchufe.
USB Cables and socket.
Câbles USB et prise électrique.
Cabos USB e plug.

SISTEMAS DE APERTURA / OPENING SYSTEM / SYSTÈMES D'OUVERTURE / SISTEMA DE ABERTURA

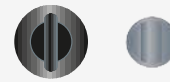

Pomo en poliamida / metálico.
Padlockable polyamide Lock / metallic Lock.
Serrure à porte cadenas en polyamide / métallique.
Fechadura de cadeado em poliamida / metal.



Cerradura de combinación y llave de emergencia.
Manual combination lock with emergency key.
Serrure à combinaison de 4 chiffres et clé de secours.
Fechadura de combinação e chave de emergência.



Monedero con moneda retornable/con cajetín depósito.
Coin-operated Lock with coin-return/collect box.
Monnayeur avec monnaie retournable/tirelire.
Moedeiro moeda retornável/caixinha.

OPCIONES / OPTIONS / OPTIONS / OPÇÕES



Ranura buzón.
Mailbox Slot.
Fente boîte aux lettres.
Obertura para cartas.



Patas en acero pintado.
Painted steel legs.
Pieds en acier peint.
Pés em aço pintado.



Pintura antibacteriana.
Antibacterial paint.
Peinture antibactérienne.
Tinta antibacteriana.



Pulsera de nylon.
Nylon bracelet.
Bracelet en nylon.
Pulseira de náilon.



Pulsera elástica.
Elastic Bracelet.
Bracelet élastique.
Pulseira elástica.



Ruedas 360° con freno. 2 de ellas con freno.
Wheels 360° with brake. 2 of them with break.
Roues 360° avec frein. 2 avec frein.
Rodas 360° com freio. 2 com freio.



Cerraduras electrónicas de combinación de 4 dígitos.
Electronic combination locks of 4 digits.
Serrures électroniques à combinaison de 4 chiffres.
Fechaduras electrónicas, combinação de 4 dígitos.



Cerraduras de proximidad.
RFID Locks.
Serrures de proximité.
Fechaduras de proximidade.

COLORES OPCIONALES PUERTAS Y CUERPO / OPTIONAL DOOR AND BODY COLOURS / COULEURS EN OPTION POUR CORPS ET PORTES / CORES DE PORTAS E CORPO OPCIONAIS



RAL 9010 RAL 9001 RAL 1017 RAL 1021 RAL 2004 RAL 4010 RAL 3017 RAL 3000 RAL 3005 RAL 4005 RAL 6029 RAL 6034 RAL 5015 RAL 5023 RAL 5010 RAL 8025 RAL 7035 RAL 9006 RAL 7036 RAL 7016 RAL 9005



SERIE SVE

1 Puerta
Door
Porte
Porta

+1 Puerta de control
Control door
Porte de contrôle
Portão de controlo



SERIE STE

2 Puertas
Doors
Portes
Portas

+1 Puerta de control
Control door
Porte de contrôle
Portão de controlo



SERIE SME

3 Puertas
Doors
Portes
Portas

+1 Puerta de control
Control door
Porte de contrôle
Portão de controlo



SERIE SCE

4 Puertas
Doors
Portes
Portas

+1 Puerta de control
Control door
Porte de contrôle
Portão de controlo



SERIE SPE

5 Puertas
Doors
Portes
Portas

+1 Puerta de control
Control door
Porte de contrôle
Portão de controlo



SERIE SBE

6 Puertas
Doors
Portes
Portas

+1 Puerta de control
Control door
Porte de contrôle
Portão de controlo



SERIE SZE

8 Puertas
Doors
Portes
Portas

+1 Puerta de control
Control door
Porte de contrôle
Portão de controlo



SERIE S10E

10 Puertas
Doors
Portes
Portas

+1 Puerta de control
Control door
Porte de contrôle
Portão de controlo



Autocierre/Self closing/
Fermeture automatique/Fechamento automático.



Cables USB y enchufe/USB Cables and socket/
Câbles USB et prise électrique/Cabos USB e plug.

SERIE SVe

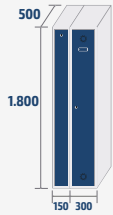

SV-30/1e
COD: 72000

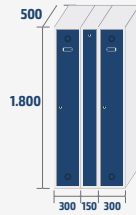

SV-30/2e
COD: 72001

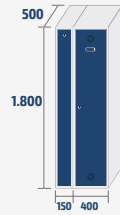

SV-40/1e
COD: 72002

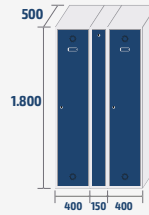

SV-40/2e
COD: 72003

SERIE STe



ST-30/1e
COD: 72004



ST-30/2e
COD: 72005

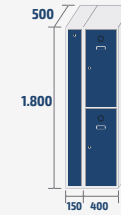

ST-40/1e
COD: 72006



ST-40/2e
COD: 72007

SERIE SMe

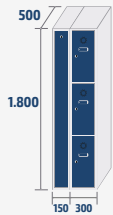

SM-30/1e
COD: 72008

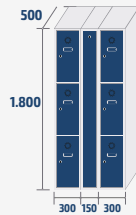

SM-30/2e
COD: 72009



SM-40/1e
COD: 72010

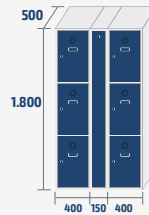

SM-40/2e
COD: 72011

SERIE SCe



SC-30/1e
COD: 72012



SC-30/2e
COD: 72013

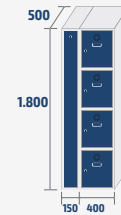

SC-40/1e
COD: 72014



SC-40/2e
COD: 72015

SERIE SPe

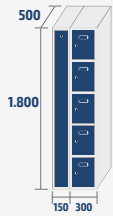

SP-30/1e
COD: 72016



SP-30/2e
COD: 72017

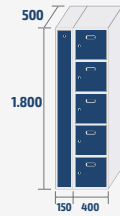

SP-40/1e
COD: 72018

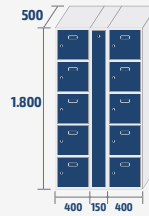

SP-40/2e
COD: 72019

SERIE SBe



SB-30/1e
COD: 72020



SB-30/2e
COD: 72021

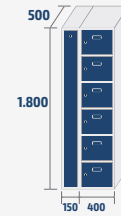

SB-40/1e
COD: 72022

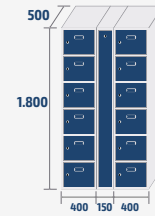

SB-40/2e
COD: 72023

SERIE SZe

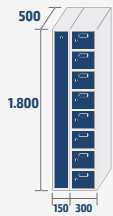

SZ-30/1e
COD: 72024

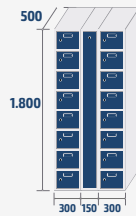

SZ-30/2e
COD: 72025



SZ-40/1e
COD: 72026



SZ-40/2e
COD: 72027

SERIE S10e

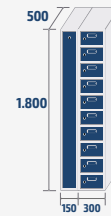

S10-30/1e
COD: 72058



S10-30/2e
COD: 72059

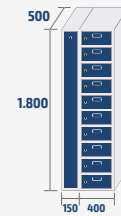

S10-40/1e
COD: 72060

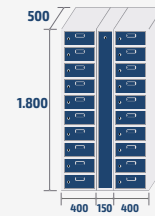

S10-40/2e
COD: 72061

OPEN SPACES



MAILBOX











Envolvente: Melamina
 Enveloping: Melamine
 Enveloppe: Mélamine
 Envelopagem: Melamina

Puertas: Melamina
 Doors: Melamine
 Portes: Mélamine
 Portas: Melamina

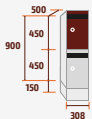
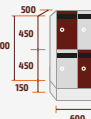

Opción cajón / Drawer option /
 Option caisson / Opção de gaveta

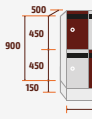
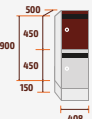
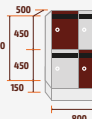
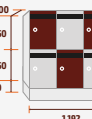
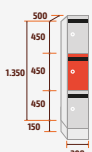
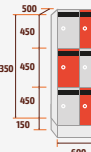
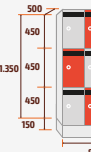
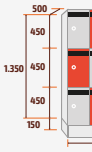
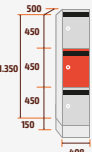
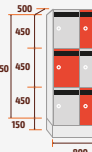
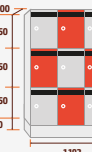
						
MAILBOX-A-30/1	MAILBOX-A-30/2	MAILBOX-A-30/3	MAILBOX-A-30/4	MAILBOX-A-40/1	MAILBOX-A-40/2	MAILBOX-A-40/3
						
MAILBOX-B-30/1	MAILBOX-B-30/2	MAILBOX-B-30/3	MAILBOX-B-30/4	MAILBOX-B-40/1	MAILBOX-B-40/2	MAILBOX-B-40/3
						
MAILBOX-C-30/1	MAILBOX-C-30/2	MAILBOX-C-30/3	MAILBOX-C-30/4	MAILBOX-C-40/1	MAILBOX-C-40/2	MAILBOX-C-40/3

OFFICE NEW



Envolvente: Melamina
 Enveloping: Melamine
 Enveloppe: Mélamine
 Envelopagem: Melamina

Puertas: Fenólico
 Doors: HPL
 Portes: Stratifié
 Portas: Resinas fenólicas



CUBIC 



Envolvente: Melamina
 Enveloping: Melamine
 Enveloppe: Mélamine
 Envelopagem: Melamina

Puertas: Fenólico
 Doors: HPL
 Portes: Stratifié
 Portas: Resinas fenólicas

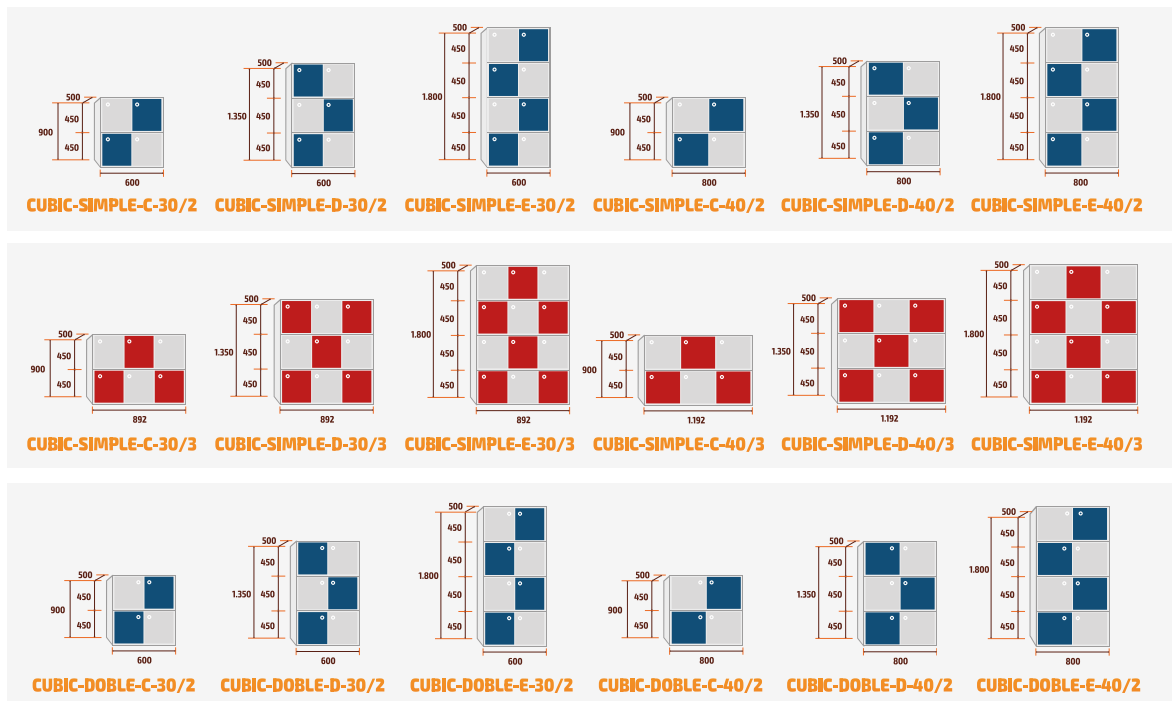



NOVEDADES

NOVELTIES / NOUVEAUTES / NOVIDADES

MOBILIARIO AUXILIAR PARA OFICINA Y HOGAR

AUXILIARY FURNITURE FOR OFFICE AND HOME

MOBILIER AUXILIAIRE POUR BUREAU ET MAISON

MÓVEIS AUXILIARES PARA ESCRITÓRIO E CASA



SERIE **DRAWER/P**

Se sirve montado.
Delivered assembled.
Fourni monté.
Fornecemos montado.



SERIE **COMODA**

Se sirve desmontado.
Delivered disassembled.
Fourni démonté.
Fornecemos desmontado.



SERIE **STUDY/A**

Se sirve desmontado.
Delivered disassembled.
Fourni démonté.
Fornecemos desmontado.



SERIE **STUDY/B**

Se sirve desmontado.
Delivered disassembled.
Fourni démonté.
Fornecemos desmontado.

SISTEMAS DE APERTURA / OPENING SYSTEMS / SYSTÈMES D'OUVERTURE / SISTEMA DE ABERTURA



Pomo en poliamida / metálico.
Padlockable polyamide Lock / metallic Lock.
Serrure à porte cadenas en polyamide/métallique.
Fechadura de cadeado em poliamida / metal.



Cerradura de combinación y llave de emergencia.
Manual combination lock with emergency key.
Serrure à combinaison de 4 chiffres et clé de secours.
Fechadura de combinação e chave de emergência.



Tirador metálico.
Metal handle.
Poignée en métal.
Cabo de metal.



Imán.
Magnet.
Aimant.
Magnético.



Cerraduras electrónicas de combinación de 4 dígitos.
Electronic combination locks of 4 digits.
Serrures électroniques à combinaison de 4 chiffres.
Fechaduras electrónicas, combinação de 4 dígitos.



Cerraduras de proximidad.
RFID Locks.
Serrures de proximité.
Fechaduras de proximidade.

COLORES OPCIONALES / OPTIONAL COLOURS / COULEURS EN OPTION / CORES OPCIONAIS



RAL 9010	RAL 9001	RAL 1017	RAL 1021	RAL 2004	RAL 4010	RAL 3017	RAL 3000	RAL 3005	RAL 4005	RAL 6029	RAL 6034	RAL 5015	RAL 5023	RAL 5010	RAL 8025	RAL 7035	RAL 9006	RAL 7036	RAL 7016	RAL 9005
----------	----------	----------	----------	----------	----------	----------	----------	----------	----------	----------	----------	----------	----------	----------	----------	----------	----------	----------	----------	----------

SERIE STUDY

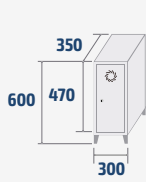

STUDY-30/A
COD: 45030

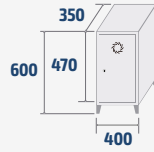

STUDY-40/A
COD: 45033

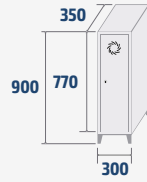

STUDY-30/B
COD: 45035

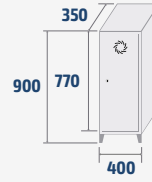

STUDY-40/B
COD: 45034

SERIE DRAWER



DRAWER-30
COD: 45055

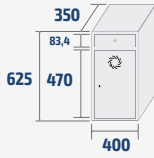

DRAWER-40
COD: 45056

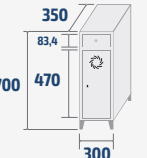

DRAWER-30/P
COD: 45057



DRAWER-40/P
COD: 45058

SERIE COMODA

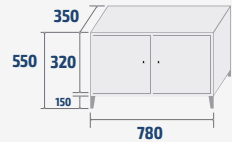

COMODA
COD: 45036



Metal.
Metal.
Metal.
Metal.



ZAPATEROS
SHOE STORAGE BOXES
RANGE-CHAUSSURES
SAPATEIRO

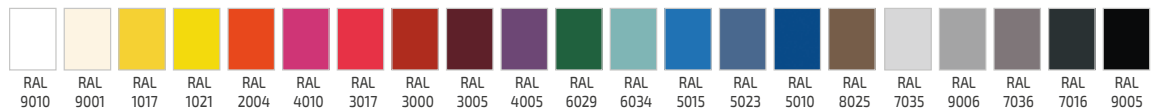

Metal.
Metal.
Metal.
Metal.

MODELO ZAP/15



SERIE ZAP/15

ZAP-151 COD: 37093 4kg	ZAP-152 COD: 37094 9kg	ZAP-153 COD: 37095 14kg	ZAP-154 COD: 37096 19kg

MODELO ZAP/20



SERIE ZAP/20

ZAP-201 COD: 37097 5kg	ZAP-202 COD: 37098 11,25kg	ZAP-203 COD: 37099 17,5kg	ZAP-204 COD: 37100 23,75kg



ARMARIO PERCHERO INDIVIDUAL
INDIVIDUAL WARDROBE CABINET
ARMOIRE PENDERIE INDIVIDUEL
CACIFO CABIDEIRO INDIVIDUAL



Metal.
 Metal.
 Metal.
 Metal.

SERIE ALONE



ALONE-16/1
 COD: 37300



ALONE-16/2
 COD: 37301

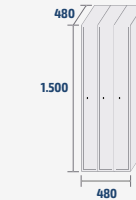

ALONE-16/3
 COD: 37302



ALONE-16/4
 COD: 37303

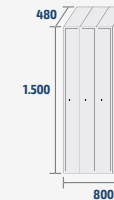

ALONE-16/5
 COD: 37304



ALONE-16/6
 COD: 37305

SISTEMAS DE APERTURA / OPENING SYSTEM /
SYSTÈMES D'OUVERTURE / SISTEMA DE ABERTURA



ESTÁNDAR

Cerradura de resbalón.
 Latch operated lock.
 Serrure à fermeture par glissement.
 Fechadura de segurança.



Monedero con moneda retornable/con cajetín depósito.
 Coin-operated Lock with coin-return/collect box.
 Monnayeur avec monnaie retornable/tirelire.
 Moedeiro moeda retornável/caixinha.



Cerradura de combinación y llave de emergencia.
 Manual combination lock with emergency key.
 Serrure à combinaison de 4 chiffres et clé de secours.
 Fechadura de combinação e chave de emergência.



Tirador metálico.
 Metal handle.
 Poignée en métal.
 Cabo de metal.



Cerraduras electrónicas de combinación de 4 dígitos.
 Electronic combination locks of 4 digits.
 Serrures électroniques à combinaison de 4 chiffres.
 Fechaduras electrónicas, combinação de 4 dígitos.



Cerraduras de proximidad.
 RFID Locks.
 Serrures de proximité.
 Fechaduras de proximidade.

OPCIONES / OPTIONS / OPTIONS / OPÇÕES



Patas de acero.
 Painted steel legs.
 Pieds en acier peint.
 Pés em aço pintado.



Puerta en melamina.
 Melamine door.
 Porte en mélamine.
 Porta a madeira de tola.



Puerta fenólica.
 HPL door.
 Porte en stratifié.
 Porta fenólica.



Ruedas 360° con freno. 2 de ellas con freno.
 Wheels 360° with brake. 2 of them with brake.
 Roues 360° avec frein. 2 roues avec frein.
 Rodas 360° com freio. 2 com freio.

COLORES OPCIONALES / OPTIONAL COLOURS / COULEURS EN OPTION / CORES OPCIONAIS

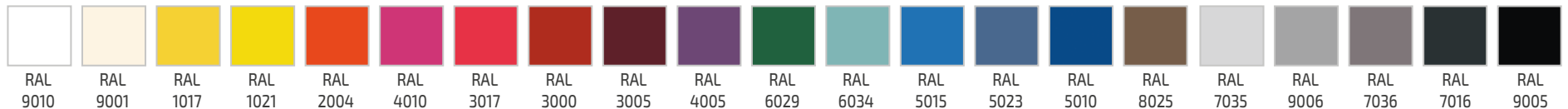

MEGABLOK

www.megablok.com

Plataforma logística PLA-ZA, C/ Palermo, 7
50197 ZARAGOZA (SPAIN)

Tels. (+34) 976 50 54 88

Fax (+34) 976 50 36 60

Móvil (+34) 696 65 57 71

E-mail: comercial@megablok.com

France 01 84 88 40 46 Contactez nous

